



**Commercial Self-Powered Cycle
Owner's Manual
C846i**

Owner's Manual

When using the Precor self-powered C846i Recumbent or C846i Upright cycle, basic precautions should always be followed, including the following:

- To ensure your safety and to protect the unit, read all the instructions before assembling and using the self-powered C846i.
- To ensure the proper use and safety of the unit, make sure that all users read this manual. Please make this manual a part of your club's training program. Remind the club users that before beginning any fitness program, they should obtain a complete physical examination from their physician.

Il est conseillé de subir un examen médical complet avant d'entreprendre tout programme d'exercice. Si vous avez des étourdissements ou des faiblesses, arrêtez les exercices immédiatement.

DANGER — To reduce the risk of electrical shock, always unplug the C846i from the optional power adapter before cleaning or performing any maintenance tasks.

WARNING — To reduce the risk of burns, fire, electric shock, or injury to persons, take the following precautions:

- Do not allow children or those unfamiliar with its operation on or near the C846i. Do not leave children unsupervised around the C846i.
- Never leave the C846i unattended with the optional power adapter plugged in. Unplug the unit when it is not in use, before cleaning it, and before putting on or taking off parts.
- Assemble and operate the C846i on a solid level surface. Locate the C846i a few feet from walls or furniture. Check the unit before each use and verify that all fasteners are secure. Maintain the C846i in good working condition. (Refer to the *Maintenance* section.)
- Use the C846i only for its intended use as described in this manual. Do not use accessory attachments that are not recommended by the manufacturer, as such attachments might cause injuries.
- Use care when getting on or off the C846i. Keep your body and head facing forward. Never attempt to turn around on the C846i.
- Wear proper exercise clothing and shoes during a workout. Do not wear loose clothing. Tie long hair back.
- Do not rock the unit. Do not stand on the display console or casing.
- Never drop or insert any object into any opening. Keep towels and hands away from moving parts.
- If you purchased the optional chest strap, review the guidelines found in the manual that is supplied with that option.
- Do not overexert yourself or work to exhaustion. If you feel any pain or abnormal symptoms, stop your workout immediately and consult your physician.

SAVE THESE INSTRUCTIONS

- Keep all electrical components away from liquids to prevent shock. Do not set anything on the casing, handlebars, or display console. Place liquids only in the appropriate receptacles.
- Never place your hands or feet in the path of the pedal because injury may occur to you or damage may occur to the equipment.
- Never operate the unit if it is damaged, if it is not working properly, if it has been dropped, or dropped in water. Return the unit to a service center for examination and repair.
- Keep the optional power adapter cord away from heated surfaces.
- Do not operate where aerosol (spray) products are being used or where oxygen is being administered.
- Do not use outdoors.
- Do not attempt to service the C846i yourself other than the assembly and maintenance instructions found in this manual. Refer to *Obtaining Service*.

HAZARDOUS MATERIALS AND PROPER DISPOSAL

The self-powered C846i has an internal battery that must be removed before the C846i is scrapped. The battery contains materials that are considered hazardous to the environment. Federal law requires proper disposal of the battery.

SAFETY APPROVAL

When identified with the ETL-c logo, the C846i has been tested and conforms to the requirements of CAN/CSA-E-335-1/3-94, Safety of Household and Similar Electrical Appliances.

EUROPEAN APPLICATIONS

This product conforms to the requirements of the European Council Directive 89/336/EEC, Electromagnetic Compatibility and has been tested to the following standards:

EN55022, Limits & Methods of Measurement of Radio Interference, Information Technology Equipment (Class A).

EN50082-1, Generic Immunity Standard for Residential, Commercial and Light Industrial Products (Class A).

This product additionally conforms to the requirements of the European Council Directive 73/23/EEC, Low Voltage Directive and has been tested to the following standard:

IEC 335-1, Safety of Household and similar Electrical Appliances.

Important: *In a domestic environment, this product may cause radio interference, in which case the user is responsible to take adequate measures to alleviate the interference.*

SAVE THESE INSTRUCTIONS

IMPORTANT SAFETY INSTRUCTIONS

Table of Contents

Important Safety Instructions	2
Hazardous Materials and Proper Disposal	3
Safety Approval	3
European Applications	3
Radio Frequency Interference (RFI)	6
C846i Self-Powered Features	6
Obtaining Service	7
About this Manual	7
Unpacking the C846i	8
Standard Equipment	8
Other Equipment	8
Setting Up the C846i	9
Hardware Kit	9
Installation Requirements	9
Additional Tools Needed	10
Assembly Instructions	10
Supplying Power to the C846i	14
Testing the Heart Rate Display	14
Club Information	15
The Club Settings	15
Programming Tips	16
Changing the Units of Measure	17
Setting a Workout Time Limit	17
Setting a Pause Time Limit	18
Limiting the Resistance Range	18
Customizing a Program	19
Viewing the Odometer, Hours of Use, Software Version, and Error Log	19
Using CSAFE Standard Equipment	21
The Display Console	22
Features on the Display Console	22
SmartRate Display	22
Upper Display	23
Informational Displays Prior to Shutdown	23
Lower Display	24
Keys on the Display Console	26
Keypad Tips	26

Table of Contents

Exercising on the C846i	29
Adjusting the Seat	29
Using the Heart Rate “Touch” Capability	30
Workout Tips	30
Quick Steps to Exercising	31
Cooling Down After a Workout	32
Pause, Cool Down, and Exit Features	32
Selecting a New Program During a Workout	34
Programs	35
Program Features	35
The Heart Rate Feature and Target Zones	36
The SmartRate Feature	37
Manual Mode and the QUICKSTART Key	38
Cross Country and Hill Climb Programs	38
Random Program	39
Interval Programs	39
Watts Control Program	39
Heart Rate Control Program	40
Weight Loss Program	40
Resistance Custom Program	40
Goal-based Programs	41
Fitness Test	41
Fitness Test Guidelines	41
Fitness Test Scores	42
Maintenance	43
Inspection	43
Cleaning the Equipment	43
Storing the Chest Strap	43
Adjusting the Seat Tilt	44
Adjusting the Seat’s Side-to-Side Movement on the C846i Recumbent	45
Using the Optional Power Adapter	46
Servicing the C846i and Long Term Storage	47
Heart Rate Troubleshooting Tips	47
Warranty Registration Card	50
Commercial Equipment Limited Warranty Statement	51
Specifications	back cover

RADIO FREQUENCY INTERFERENCE (RFI)

Federal Communications Commission Part 15

The C846i has been tested and found to comply with,

- the IEC EMC Directive (international electromagnetic compatibility certification)
- the limits for a Class A digital device, pursuant to Part 15 of the FCC Rules. These limits are designed to provide reasonable protection against harmful interference in a commercial installation. The C846i generates, uses, and can radiate radio frequency energy and, if not installed and used in accordance with the owner's manual instructions, may cause harmful interference to radio communications. Operation of the C846i in a residential area is likely to cause harmful interference. If this occurs, the user will be required to correct the interference at his or her own expense.

WARNING — **Per the requirements of the Federal Communications Commission, changes or modifications to this product, not expressly approved by Precor, could void the user's authority to operate the product.**

Canadian Department of Communications

This digital apparatus does not exceed the Class A limits for radio noise emissions from digital apparatus set out in the Radio Interference Regulations of the Canadian Department of Communications.

Le présent appareil numérique n'émet pas de bruits radioélectriques dépassant les limites applicables aux appareils numériques de la Class A prescrites dans le Règlement sur le brouillage radioélectrique édicté par le ministère des Communications du Canada.

C846i SELF-POWERED FEATURES

The power source for the C846i is the user. When a person exercises on the C846i and moves the foot pedals at a pedal speed above 20 revolutions per minute (RPM), the power that is generated allows the C846i to function properly. Informational displays appear when the battery is low or when the user has stopped pedaling during a workout. The display provides minimal instructions to let you know what to do to retain power. If the messages are ignored, the C846i will begin shutdown procedures to maintain the charge of the battery. Refer to *Informational Displays Prior to Shutdown*.

An optional power adapter can be purchased and provides sustained power to the C846i. If you plan to customize your unit (refer to *Club Settings* section), the optional power adapter is highly recommended. To purchase the optional power adapter, check with your dealer.

OBTAINING SERVICE

Do not attempt to service the self-powered C846i yourself except for the maintenance tasks described in this manual. The C846i does not contain any user-serviceable parts. For information about product operation or service, contact an authorized Precor Commercial Products Customer Support Representative at 1-888-665-4404.

To help customer support personnel expedite your call, have your serial number available. The serial number can be found on a label near the optional power adapter receptacle on the side of the cycle.

Model number: **C846i**

Unit number: _____ Serial number: _____

Unit number: _____ Serial number: _____

Unit number: _____ Serial number: _____

ABOUT THIS MANUAL

Inside this manual, you will find instructions for installing and using the self-powered C846i. To maximize the use of the C846i, please study this manual thoroughly. The manual uses the following conventions for identifying special information:

Note: Contains additional information that applies to the preceding text.

Important: *Indicates information to which you should pay special attention.*

CAUTION: Indicates steps or information necessary to prevent harm to yourself or damage to the equipment.

WARNING — Provides instructions to prevent electrical damage to the equipment and prevent injuries to yourself.

DANGER — Indicates steps you must take to prevent electrical shock.

Unpacking the C846i

Thank you for purchasing the Precor self-powered C846i. Built to the exacting standards of the health club environment, the C846i is intended for commercial use and can withstand the rigors of daily club use with little maintenance.

Important: Before using the C846i, we urge you to familiarize yourself and your staff with the entire Owner's Manual. Understanding this manual will help you and other personnel use the C846i safely and successfully.

The C846i Upright or C846i Recumbent cycle is carefully tested and inspected before shipment so it should arrive in good operating condition. Precor ships the unit in the following pieces:

- Base frame assembly
- Front assembly (includes display console and, on the C846i Upright, handlebars)
- Owner's Manual, hardware kit, and limited warranty registration card

CAUTION: The C846i is heavy (up to 170 pounds or 77 kilograms). To avoid injury and ensure the safety of the unit and yourself, we suggest that you get assistance before removing the unit from the box.

If any items are missing, contact Precor Commercial Products Customer Support. Refer to *Obtaining Service*.

STANDARD EQUIPMENT

The C846i incorporates the Precor SmartRate® and heart rate features into its display console. Devices, such as FitLinxx®, that are CSAFE compatible, can also be attached.

The Precor “touch” heart rate is standard. It provides electrode strips, called “grips,” on the handlebars. When a user places both hands over the grips and grasps the handlebars, a heart rate is transmitted to the receiver.

Note: If a user does not wish to use the touch-sensitive hand grips, an optional chest strap can be purchased and worn. The chest strap transmits the user's heart rate to the display console's receiver.

OTHER EQUIPMENT

Optional equipment available through your dealer includes:

- Chest strap
- Power adapter

If you are interested in obtaining Precor option kits for your unit, check with your dealer. For customer support, refer to *Obtaining Service*.

Setting Up the C846i

You do not need any special knowledge or experience to set up the cycle. However, because of its size and weight, you will need to obtain assistance.

HARDWARE KIT

After unpacking the cycle, open the hardware kit and make sure that you have the following items shown in Diagram 1.

- (A) rubber bib
- (B) two hex head cap screws
- (C) two large washers
- (D) four 1 $\frac{3}{4}$ -inch buttonhead screws (The four buttonhead screws are used in the assembly of the C846i Recumbent cycle. If you purchased the C846i Upright, you can discard the buttonhead screws.)
- (E) $\frac{3}{16}$ -inch hex key

Diagram 1 Hardware kit (not shown to scale).

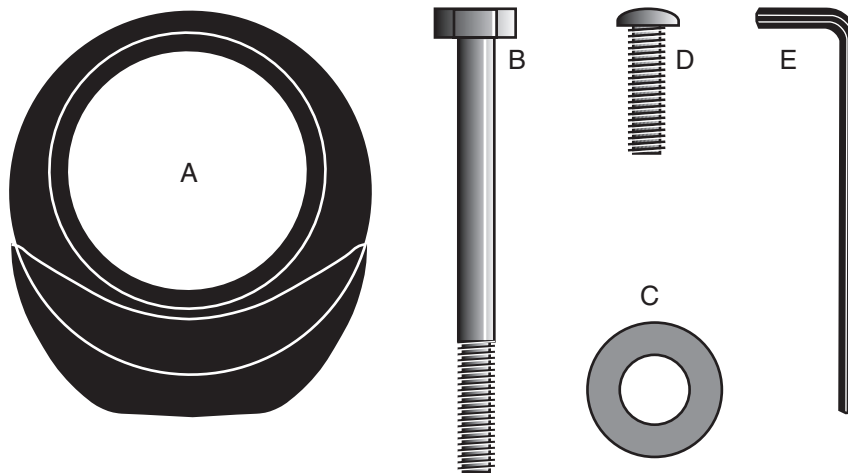

INSTALLATION REQUIREMENTS

Follow these installation requirements when installing the C846i. *If you do not install the C846i according to the following guidelines, you could void the Precor Limited Warranty.*

- **Set up the C846i on a solid, flat surface.** Assemble the C846i close to where you will use it. Make sure that the flat surface under the unit is smooth and level. A level unit is required for the user's safety and for proper operation.
- **Provide ample space around the unit.** Open space around the unit makes for a safer mount and dismount.
- **Fill out and mail the limited warranty card.** The serial number is located on a label near the optional power adapter receptacle. Write the serial number onto the Precor Limited Warranty card found on the back cover of this manual. Refer to *Obtaining Service* and write the number there as well.

ADDITIONAL TOOLS NEEDED

Obtain the following tools *before* assembling the C846i.

- 3/4-inch box end wrench or crescent wrench
- Wire cutter

ASSEMBLY INSTRUCTIONS

Take the following steps to assemble the C846i Upright and C846i Recumbent cycle.

Note: The C846i Upright and C846i Recumbent have similar assembly instructions except for adjusting the seat.

1. **Obtain assistance.** Ask for assistance to help assemble the C846i. Have the assistant(s) place the shipping carton close to the location where you plan to use the C846i. Breakdown the sidewalls of the shipping carton so that they lie flat.
2. **Remove the front and base assemblies.** The front assembly is composed of the upright support and display console. The base assembly is composed of the base support, seat, pedals, and rear casing. Place the two assemblies close to each other so that it will be easy to connect the cables and secure the sections together. Refer to Diagram 2.

CAUTION: Disconnect the C846i from any external power source.

3. **If necessary, unplug the C846i from its optional power adapter.**
4. **Remove the two hex head cap screws (B) and two large washers (C) from the hardware kit.** Place a washer on each screw and set them aside.
5. **Attach the upright support to the base assembly.** Diagram 2. Before securing the upright support to the base assembly, you need to add the rubber bib, from the hardware kit, to the base of the upright support and attach the upper and lower electronic cables. To do this, take the following steps:
 - a. Place the rubber bib on the base of the upright support as shown in Diagram 2, #1.

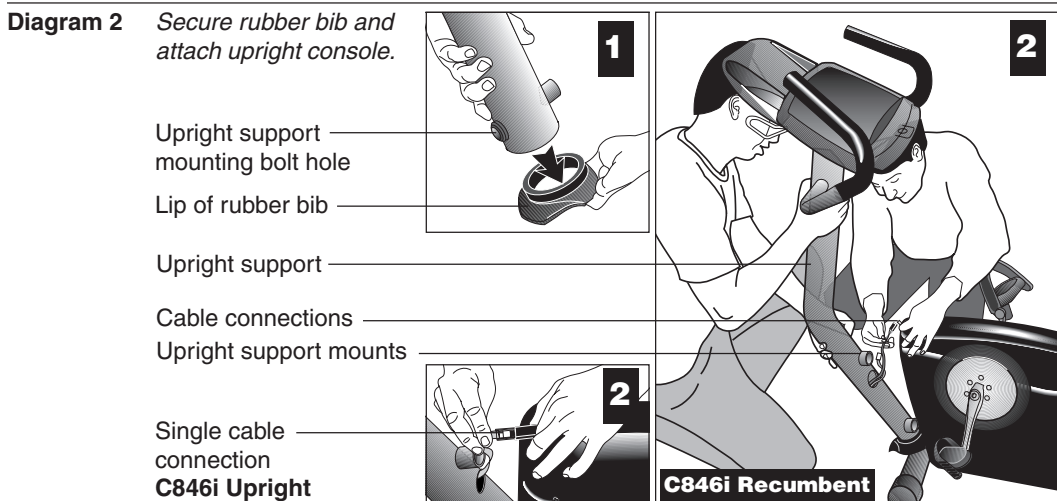

- b. Position the base of the upright support onto the rim of the boot so that the lip of the rubber bib will rest on the cycle's crossbar.
- c. Connect the cables as shown in Diagram 2, #2. Locate the cables found inside the base assembly. Ask an assistant to hold the upright support close to the base assembly, while you connect the cables. The connectors are designed to slide easily into the receptacles. **Do not force the connection.**

Important: The C846i Upright has one cable to receptacle connection while the C846i Recumbent has two cables and receptacles.

CAUTION: Do not crimp or pinch the cable! Carefully, place the excess cable inside the base before you secure the upright support to the base assembly. Crimped or pinched cables are not covered by the Precor Limited Warranty.

Diagram 3 *Securing the upright support to the base assembly.*

- Hex head cap screw (B) and washers (C)
- Upright support
- Base assembly

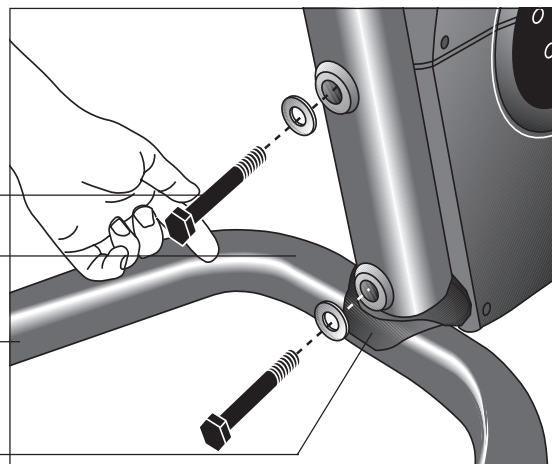

Check that the rubber bib is parallel to the floor.

- 6. **Secure the upright support to the base assembly.** Diagram 3. Align the two upright support mounts with the base assembly. Insert the two hex head cap screws (B) with washers (C) through the upright support and into the base mounts. Before tightening the screws, check that the cables are not in danger of being crimped or pinched and that the lip of the rubber bib overlaps the front crossbar and is parallel to the floor.
- 7. **Tighten the hex head cap screws (B).** Alternately tighten each screw using a 3/4-inch box-end wrench or crescent wrench. Check to make sure that the upright support is secure.
- 8. **Attach the seat pad (C846i Recumbent only).** If you purchased a recumbent cycle, you will need to attach the upper portion of the seat pad.
 - a. Position the seat pad as shown in Diagram 4, #1 and slide it along the seat frame until it comes to rest. The upper portion of the pad rests on the top of the two seat frame posts.

Diagram 4 C846i Recumbent seat pad installation.

Buttonhead screw (D) —
Insert the screws by hand
and finger tighten.

Upper portion of seat pad

Seat frame (post)

$\frac{3}{16}$ -inch hex key (E)

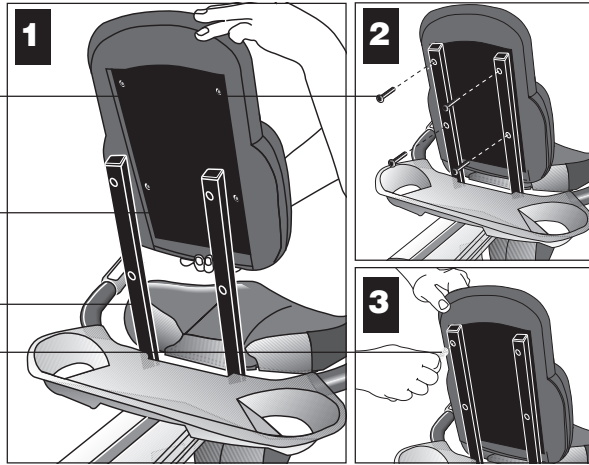

CAUTION: The next step is critical! The back of the seat pad has nut inserts for the buttonhead screws (D). It is critical that you hand thread the four screws. Otherwise, the nut inserts can be stripped and the seat pad will have to be replaced at your cost. Improper assembly is not covered by the Precor Limited Warranty.

- b. Insert four buttonhead screws (D) and *finger tighten*.
- c. With the four buttonhead screws (D) properly threaded, use the supplied hex key (E) to alternately tighten each screw until it is snug against the seat frame.

Diagram 5 Adjusting the seat on the C846i Upright.

Seat

Seat post adjustment
pin (pop pin)

Seat post support

Seat post

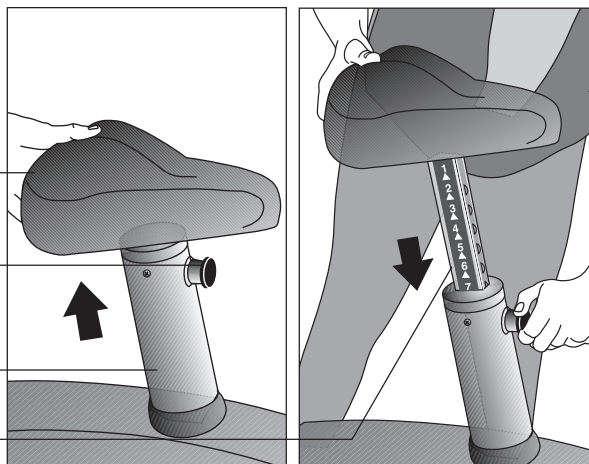

9. **Adjust the seat.** Diagrams 5 and 6. On the C846i Upright, you simply pull up on the seat to raise it or pull the seat post adjustment pin (pop pin) out while you lower it.

CAUTION: Always make sure that the seat is securely in place before a user sits on the C846i Upright cycle.

Diagram 6 *Adjusting the seat on the C846i Recumbent.*

Accessory tray —
Heart rate touch-sensitive grips —
Seat adjustment handle —

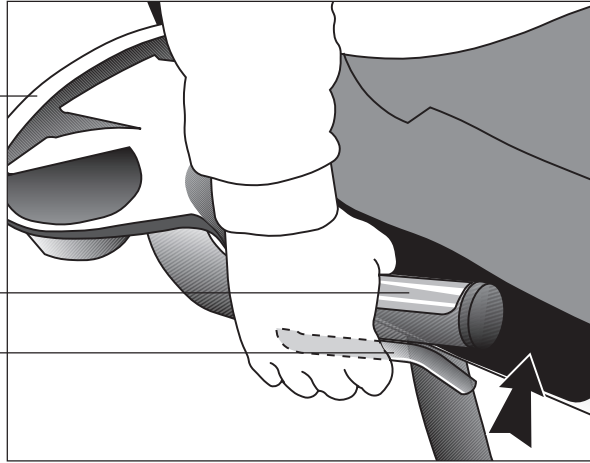

On the C846i Recumbent, you need to sit on the seat, pull up on the seat adjustment handle and use your legs to move the seat along the center post. If you notice that the seat rocks from side to side, you will need to realign the center wheel that runs inside the center post. Refer to the instructions in the *Maintenance* section of this manual.

Diagram 7 *Leveling the unit.*

Crossbar —
Level adjuster —

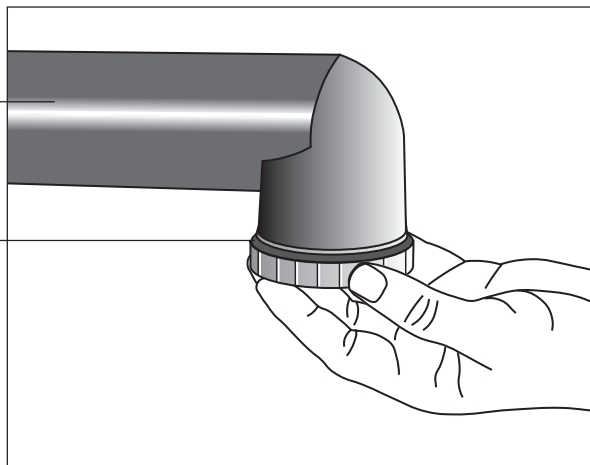

10. Level the unit. Diagram 7. Once the base and upright assembly is complete, you will need to check the unit's stability. The unit has adjustable feet that can help level the unit plus or minus $\frac{1}{4}$ -inch. If necessary, rotate the level adjusters to stabilize the unit. Turning the level adjusters *clockwise*, raises the crossbar. The adjustable feet are on the front of the C846i Upright and the rear of the C846i Recumbent.

You have completed the assembly for the C846i. Please test the heart rate display and review the rest of this manual before allowing user's access to the unit.

SUPPLYING POWER TO THE C846i

The C846i does not require an electrical power connection. It has an internal battery that is recharged every time a user exercises for a reasonable period of time. A pedaling speed above 20 revolutions per minute must be maintained for several seconds before the Precor banner appears on the display. Once the banner appears, the user can press QUICKSTART or ENTER to begin exercising. For more information, refer to *Exercising on the C846i*.

TESTING THE HEART RATE DISPLAY

Verify that the heart rate display is operational before customers begin using the cycle.

1. Sit on the cycle and begin pedaling. Maintain a pedaling speed above 20 revolutions per minute. The Precor banner will appear on the display.
2. Grab *both* metal grips on the handlebars. Refer to Diagram 8. A user must grasp **both** handlebar grips before the receiver in the display acquires the heart rate signal.

Diagram 8 *Hand placement on the handrail grips.*

Heart rate grip
C846i Recumbent

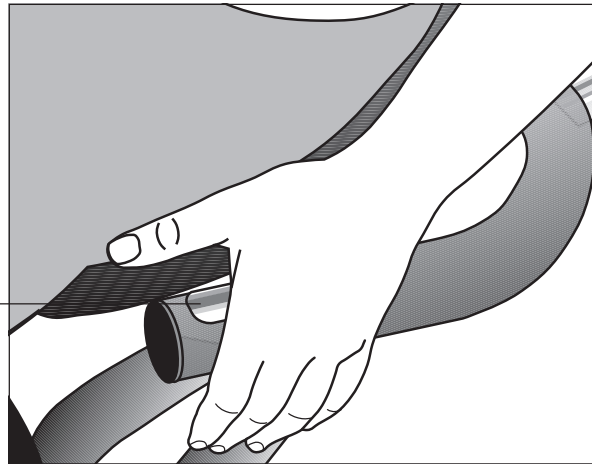

Note: To conduct electrical impulses from a user's heart, the electrode strips in the handlebar grips must be in contact with the user's skin. Usually, the concentration of salts in a person's perspiration provides enough conductivity to transmit a signal to the receiver in the display console. However some people, because of body chemistry or erratic heartbeats, cannot use the heart rate touch-sensitive feature on the C846i. A chest strap may provide better results. Refer to *Obtaining Service*.

3. Wait five to ten seconds. A number indicating your heart rate (beats per minute) should appear in the small upper right display. Refer to Diagram 9.
4. If the heart rate display appears, the cables are properly connected and the heart rate feature can be a viable part of a user's workout.
5. If the heart rate display does not appear, stop pedaling. Ask someone else to try steps 2 and 3. If no heart rate number appears, refer to *Heart Rate Troubleshooting Tips* for more information.

Club Information

These next few pages provide information that lets you customize the C846i for your club. It is not information that your customer needs to see. This section covers the following information about how to:

- Select the units of measure
- Set maximum workout and pause times
- Customize a program
- Display the odometer and other useful information
- Connect to CSAFE compatible devices

Note: If your customers are interested in learning more about the C846i, you may wish to direct them to the manual available on Precor's web site (www.precor.com). (The manual, which appears on the web site, does not contain the information found in this section.)

THE CLUB SETTINGS

The Club "custom" settings are accessed through specific codes that prevent unauthorized access. Refer to Diagram 9 to locate the keys. Information that you can access and features that can be customized are as follows:

- **Units of Measure** — Select between U.S. Standard and Metric displays.
- **Maximum Workout Time** — Sets a maximum limit on workout time.
Note: Remember the additional five-minute cool-down period appended to a completed program, so adjust the maximum time limit accordingly.
- **Maximum Pause Time** — Sets the maximum duration for which a person can pause his or her workout.
- **Limiting the Resistance Range** — Set specific resistance range (high, medium, or low) for the cycle.
- **Changing the Custom Program Resistance Settings** — Sets specific resistance settings for a custom program.
- **Odometer, Hours of Use, Software Version, Error Log and Serial Number** —The C846i stores the cumulative revolutions, the number of hours that the unit has been in use, the software version and software type (which is valuable when calling Customer Support), an error log (useful when troubleshooting), and the serial number (another valuable item when calling Customer Support).

PROGRAMMING TIPS

To access the Club settings, the following must occur:

- ❑ **Electrical power must be supplied.**
The foot pedal speed must be maintained at 20 revolutions per minute. Or, the optional power adapter must be plugged into the C846i and connected to an appropriate power source.
- ❑ **Check that the Precor banner appears on the display and maintain the minimum pedal speed.**
- ❑ **Press the appropriate key sequences.**

Important: To access Custom Club mode, press RESET at the Precor banner, and without pause, press the remaining sequences. Once you begin entering a key sequence, each key must be pressed quickly and without pause or the Precor banner reappears and you have to begin again.

The functions of the display console keys while in Custom Club mode are described in the box below. The touch-sensitive keys can be gently pressed and held to view several selections. The longer the key is held down, the faster the numbers scroll past.

Display key functions within the Custom Club Mode	
<p>▼▲ lets you scroll through the various selections that appear. The longer the key is held down, the faster the numbers scroll past.</p> <p>CHANGE reminds you what part of the program you are changing.</p>	<p>ENTER saves the information being displayed and moves to the next aspect of the program.</p> <p>RESET exits Custom Club mode and displays the Precor banner. Any previous display attributes that you selected by pressing ENTER are saved and recorded in memory.</p>

Do not use the PROGRAM CHANGE ▼▲ keys to attempt access to the Custom Club mode..

Diagram 9 Display console and keypad.

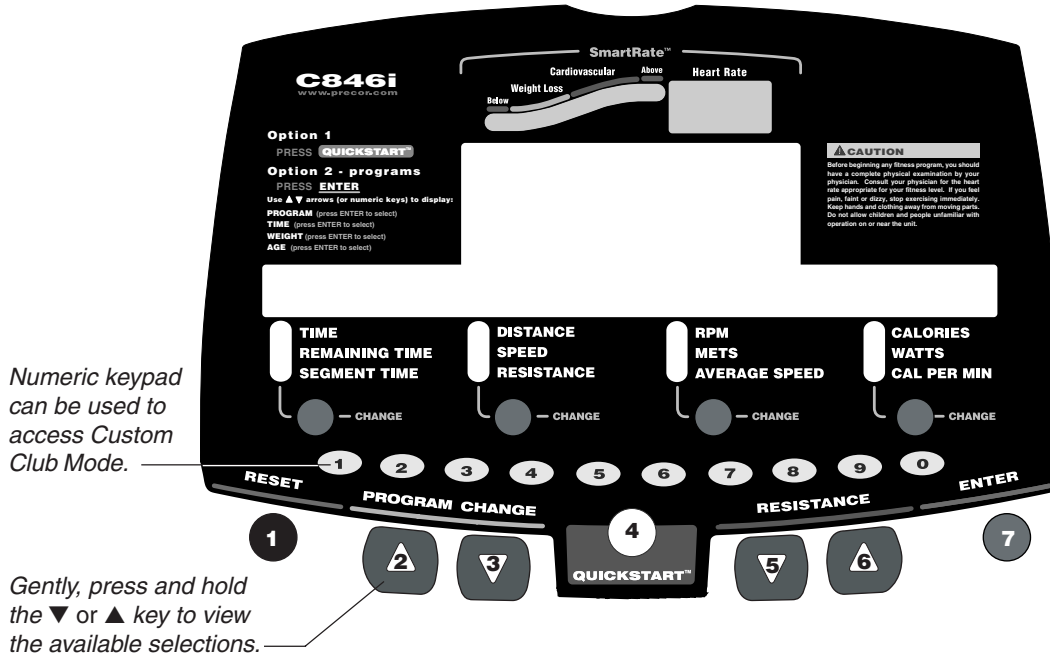

CHANGING THE UNITS OF MEASURE

To change the units of measure, set the maximum workout and pause times, or customize a program, press the following keys without pause:

RESET, RESISTANCE ▼, RESISTANCE ▲▼, RESET, RESISTANCE ▼▲▼

Note: As shown in Diagram 9, numbers are associated with keys on the keypad. Numbers will appear based on the key sequence that you pressed. After pressing the above sequence, you will see 5, 6, 5, 1, 5, 6, 5 on the display.

Two different units of measure can be selected, *Metric* or *U.S. Standard*. Make your selection using the ▼▲ keys. Press ENTER once the correct unit is displayed.

SETTING A WORKOUT TIME LIMIT

You can limit how long a user exercises by setting a duration between 1 and 240 minutes. You can also choose NO LIMIT, which allows the user to select a program and exercise indefinitely. (Note that the user must enter a workout time of zero using the *numeric* keys at the **Enter Time** prompt before he or she can exercise indefinitely.)

Important: If the club setting is NO LIMIT and the user enters zero at the **Enter Time** prompt, then the **Remaining Time** display does not appear when a user works out. (An exception to this rule is the Weight Loss program.)

Note: The workout time of any program accessed by pressing QUICKSTART™, is set at the Club limit. Refer to QUICKSTART on page 28.

Use the ▼▲ keys to select a workout time limit. For example, if you set the workout time limit to 20 minutes, the C846i allows users to specify a workout between 1 and 20 minutes. Users would not be allowed to specify a time longer than 20 minutes. Take into account that the user will get an additional five-minute cool-down period appended to his or her workout, so adjust the time limit accordingly.

SETTING A PAUSE TIME LIMIT

Use the ▼▲ keys to set a Pause time limit between 1 and 120 seconds (two minutes). Note that changes to the Pause time become effective only when the power source for the C846i is the optional power adapter. If no power adapter is connected and the pedal speed drops below 20 revolutions per minute, the C846i moves into a thirty-second shutdown mode. Refer to *Informational Displays Prior to Shutdown*.

LIMITING THE RESISTANCE RANGE

After pressing ENTER to accept the Pause time limit, you have the option to change the resistance range. The resistance range does not affect the number of resistance settings (1 through 25) that are available to the user. It determines how much resistance is felt at each resistance setting, and how big the step in resistance is from one resistance setting to the next.

The default resistant range is HIGH. It provides the full resistance available from the cycle. When the resistance range is set to HIGH and a user chooses the high-end resistance levels using the arrow keys, the cycle provides enough resistance to simulate sprinting or hill climbing for users wishing to stand on an upright cycle. It also provides enough resistance for elite riders that are capable of spinning at high speed with high resistance.

The MEDIUM resistance range provides approximately two thirds of the resistance that is available with the HIGH setting. The maximum resistance available (a user chooses a resistance setting of 25) is reduced and the change, in resistance from one resistance setting to the next, is reduced. Clubs may want to select the MEDIUM range for recumbent cycles. Since users cannot stand on a recumbent cycle, less resistance is needed by the average (non-elite) rider. The MEDIUM range allows an average user more comfort. It allows them to use more of the available resistance settings and make resistance changes in the preset programs (Hill Climb and Cross Country) easier.

The LOW resistance range provides approximately one third of the resistance that is available with the HIGH setting. The LOW range may be appropriate in special situations where deconditioned users are anticipated, but the LOW range is not recommended for the normal club environment.

CUSTOMIZING A PROGRAM

After pressing ENTER to accept the Resistance Range, the display prompts you to customize the program profile that appears on the display. The blinking segment or column indicates the portion of the program that you can change. The resistance LED is lit and a number, indicating the resistance level, appears beneath the program profile.

Note: If you wish to create a custom program for your club members, continue with the instructions below. If you prefer to exit the Custom Club mode, press ENTER, RESET, or QUICKSTART.

You can set the resistance throughout the program profile using the following keys.

Keypad Keys	How it affects the Custom Program
RESISTANCE ▼▲	lets you move between the blinking segments or columns
PROGRAM CHANGE ▲▼	lets you change the resistance for the blinking segment

The display shows the resistance number as you press the PROGRAM CHANGE keys. It also affects a change to the program profile if the resistance range is great enough.

Press ENTER to accept that changes on the display and return to the Precor banner. Press RESET if you do not wish to save the changes.

VIEWING THE ODOMETER, HOURS OF USE, SOFTWARE VERSION, AND ERROR LOG

To view the odometer, the number of hours the C846i has been in use, the software version, and any error codes, press the following keys quickly and without pause:

RESET, RESISTANCE ▲ ▼

Important: Remember to begin at the Precor banner. After pressing RESET, the next key in the sequence must be pressed quickly. You will see 6, 5 on the display as you press the associated key.

The field name **Odometer** appears briefly and then the odometer value (shown in the total cumulative revolutions) appears.

Press ENTER and the number of hours (**Hour Meter**) that the unit has been in use appears. The C846i notes the passing of each 10th of an hour, but the numeric value that appears is truncated to the nearest full hour.

Press ENTER again and the unit's three-digit software version number (upper and lower electronics board) appears on the display.

Diagram 10 Error log display.

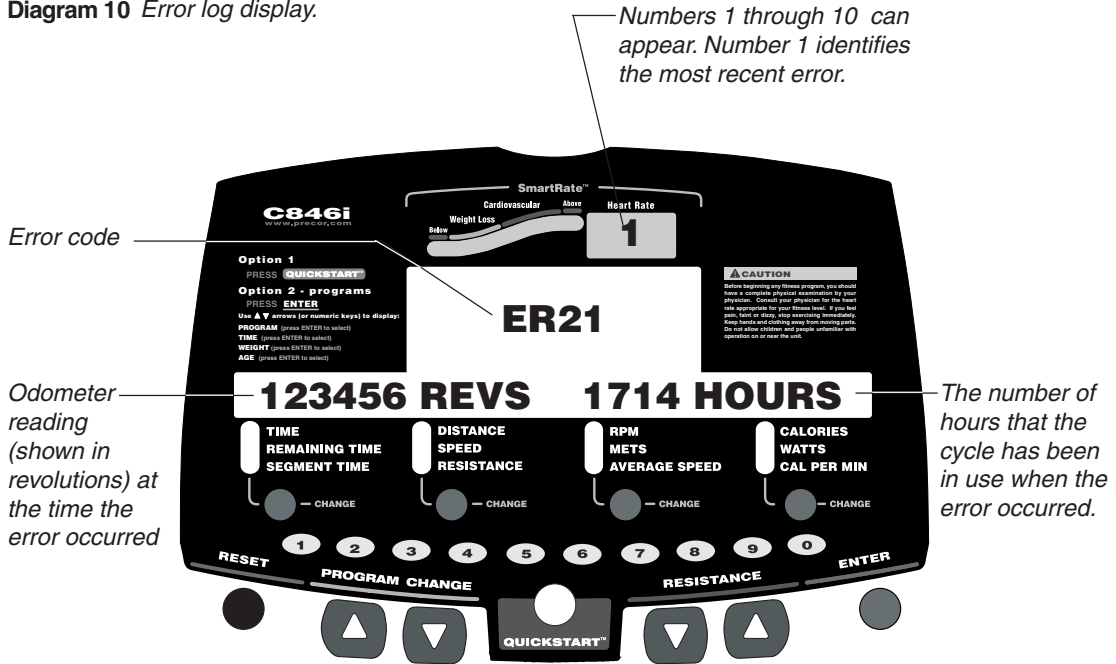

Press ENTER once again and the Error Log appears. Press the ▼ or ▲ key to view the error messages. Error logs are recorded historically. The C846i can store up to 10 error messages. Useful information, describing the different aspects of the error message, appears in Diagram 10.

Note: To clear the error logs, press QUICKSTART for at least four seconds while viewing the list. Prompts appear on the display and let you know when the error messages have been cleared from memory.

Important: You cannot retrieve the error log once you have cleared it.

To return to the Precor banner, press RESET. To view the cycle's serial number, press ENTER.

If you pressed ENTER, the field name **Serial Number** appears briefly and then the cycle's serial number appears. This number is useful when contacting Customer Support.

To return to the Precor banner, press RESET or ENTER.

USING CSAFE STANDARD EQUIPMENT

The C846i is fully compatible with CSAFE protocols. Once the unit is connected to a CSAFE master device and the user maintains a pedal speed above 20 revolutions per minute, the user is prompted to enter a user ID.

Note: If the optional power adapter is plugged into the C846i and connected to an appropriate power source, then no pedaling is necessary for user ID entry.

At the user ID prompt, five zeros appear on the display. The blinking left zero indicates that it is awaiting input. The following table provides information about the keypad functions:

User ID Entry	Program Keys
▼ or ▲	Moves the blinking LED from field to field.
Numeric keypad	Use the number keys to enter a user ID. The number that is pressed appears in the display and the next field begins to blink. When all five user ID numbers are selected, the user must press ENTER to submit it.
ENTER	Submits the displayed user ID. Note that if the five zeros are being displayed when the user presses ENTER, the user ID entry is bypassed and the program prompt appears.
RESET	Resets the display to the Precor banner.

A message indicates when the user ID is accepted by the CSAFE master device. Then, the program prompt is displayed. Refer to *Quick Steps to Exercising*.

Note: If the user's pedal speed drops below 20 revolutions per minute while using the CSAFE device connection, a prompt PEDAL FASTER appears. If the pedal speed remains below the 20 revolutions per minute threshold for the next twenty seconds, the CSAFE connection is terminated. The word RESETTING appears on the display while the C846i disconnects from the CSAFE device.

To review information about CSAFE specifications, visit the web site at:

www.fitlinxx.com/csafe

If you have questions or need technical support, refer to *Obtaining Service*.

The Display Console

The C846i is designed so users can exercise with minimal instruction or training. The directions on the console and the display prompts will guide a user through an entire workout session. Before the C846i is used, however, we recommend that you familiarize yourself with it so you can instruct your customers to use it safely and effectively. This section provides an overview of the features provided on the display console.

FEATURES ON THE DISPLAY CONSOLE

Indicator lights show which feature is being displayed. When a user exercises, the display presents **Time**, **Distance**, **RPM** (revolutions per minute), and **Calories**. Users can change what features appear on the display by pressing the CHANGE keys.

***Important:** Because the C846i is self-powered, the displays do not appear until the user maintains a pedal speed above 20 revolutions per minute. Note that there is an exception to this rule. If power is being supplied through the optional power adapter, then pedaling is not required for the Precor banner to appear. Refer to C846i Self-Powered Features.*

As a user exercises, the display console provides motivation by presenting constant feedback about his or her progress. A brief explanation of each feature on the display console appears in Diagram 11. Look on the next pages for a more thorough explanation. If an error message should appear, call a Precor qualified service technician or service center. Refer to *Obtaining Service*.

SMARTRATE DISPLAY

SmartRate: A user must enter an age during the setup prompts and wear a chest strap (or hold onto the heart-rate grips on the handlebars), while in a program, before the blinking segment in the bar graph can show the zone that his or her heart rate is in, either: weight loss or cardiovascular. Refer to *The SmartRate Feature*.

***Important:** During a program, the pedal speed must be above 20 revolutions per minute and a user's heart rate must be above 40 beats per minute before the SmartRate segment begins to blink. A user must grasp both handlebars or wear a chest strap.*

HEART RATE: The heart rate display lets a user monitor his or her heart rate. When a heart beat is detected, the number appears in the small upper right display (refer to Diagram 11). See the *Important* note above and refer to *The Heart Rate Feature and Target Zones*.

Diagram 11 *Display console.*

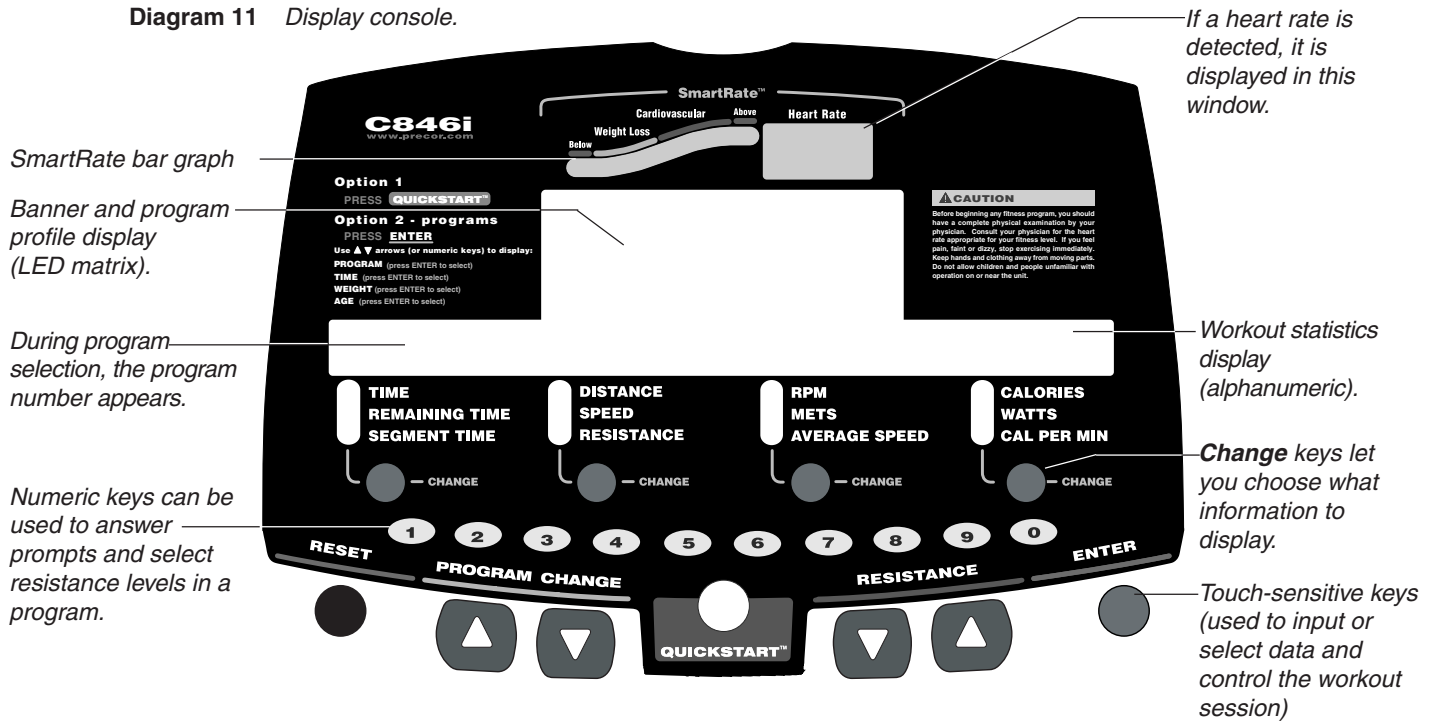

UPPER DISPLAY

The Precor banner and program profiles appear in the large center display (LED matrix). Always start a workout at the Precor banner. During workouts, the program profile appears in the center display and corresponds to the program that the user selects. As a user proceeds through a workout, a blinking column indicates his or her position.

INFORMATIONAL DISPLAYS PRIOR TO SHUTDOWN

The C846i saves its battery charge by moving into a shutdown mode. Whenever PEDAL FASTER appears on the display, the heart rate, SmartRate, and program indicators turn off. If the user does not maintain a pedal speed of 20 revolutions per minute, then a thirty-second shutdown process begins.

When twenty-eight seconds remain, the upper display appears blank and all key presses are ignored except RESET. The touch-sensitive heart rate features are also ignored. If no pedaling occurs in the next eight seconds, a row of dots (that correspond to the number of seconds remaining before the C846i shuts off) appears in the upper display.

If the C846i is connected to a CSAFE master device, a slightly different scenario occurs. When the number of seconds remaining before the C846i shuts off equals ten seconds (instead of eight), the workout session ends. RESETTING appears in the lower display while the C846i disconnects from the CSAFE master device. All key presses are ignored. Pedaling has no effect on the display.

If the battery voltage is low or needs recharging, the words **WARNING - LOW BATTERY** appear after the Precor banner. The C846i continues to function even with a low battery, but user and program information are lost once the user stops pedaling. Note that the Pause feature does not work.

When the battery voltage is low, changes to the resistance are ignored. When a user attempts to change the resistance, **LOW BATTERY** appears on the display. The program profile and calories calculations are not affected by the low battery and continue to show the programmed changes as if the changes to the resistance actually occurred.

Note: A sustained workout at the current resistance will help recharge the battery. Or, plug in the optional power adapter. Refer to the *Maintenance* section.

LOWER DISPLAY

Prompts appear in this display prior to a workout. A user addresses each prompt using the numeric or keypad keys. Once the user begins pedaling and maintains a pedal speed above 20 revolutions per minute, lights appear in the columns below the window indicating which information is being displayed. A user can highlight a particular feature by pressing the appropriate **CHANGE** key.

The following describes the information that can appear in the lower display.

TIME: During a workout, a time (0:00) display appears. **Time** appears in minutes and seconds. However, should a user exceed 60 minutes (during a single workout), the **Time** display converts to hours and minutes. The **Time** display shows how long a user has been exercising. Even when a user enters the cool-down period, the **Time** display provides the cumulative duration of the workout.

DISTANCE: The distance (00.00) that you have traveled appears once you begin a workout. The distance is related to the user's current speed. Distance appears in 100th mile increments until you reach 99.99 miles in a single workout, then miles increment by 10^{ths} (100.0). Distance can appear in miles or kilometers. If you wish to change the display, follow the instructions found in *Changing the Units of Measure*.

RPM: Indicates the number of revolutions that the pedal completes per minute. The value can range between 20 and 150.

Important: The self-powered C846i requires that a user maintain a pedal speed above 20 revolutions per minute to function properly. **PEDAL FASTER** appears on the display as a warning that the C846i is entering shutdown mode. Refer to Informational Displays Prior to Shutdown.

CALORIES: Provides the cumulative number of calories being burned.

REMAINING TIME : Indicates the amount of time, in minutes and seconds (mm:ss), that remain in the program. When a user enters a cool-down period, the **Remaining Time** resets to five minutes and begins counting down from there.

Note: If the club has set the **Workout Time Limit** as **NO LIMIT** and the user inputs 0 using the numeric keys at the time prompt, then no information appears in the **Remaining Time** display. Refer to *Setting a Workout Time Limit*.

SPEED: The displayed value is an estimate of “linear speed” even though the cycle is stationary. The value is determined by converting the user’s current RPM and resistance settings into an estimate for miles per hour (or kilometers per hour). Refer to *Changing the Units of Measure*.

METS: Displays the metabolic equivalents of the user’s current energy expenditure level. A MET’s level of 1 represents the body at rest. Note that when a user reduces pedaling intensity, the MET’s value begins to drop toward zero because the displayed information no longer corresponds to the user’s MET level.

WATTS: Indicates the amount of energy the C846i is currently generating and is derived from the current resistance and pedaling speed.

SEGMENT TIME: In the Manual or preset programs, this display indicates the amount of time, in minutes and seconds (mm:ss), that remains in the highlighted column of the program profile before the next column begins blinking. If the program being used is Interval or Weight Loss, then the number appearing in this display indicates the amount of time that remains in the current interval.

RESISTANCE: Displays the amount of resistance being applied to the pedals. The RESISTANCE ▼▲ keys let the user set a resistance between 1 and 25 which affects the amount of resistance applied by the brake. Once a program is begun, a user can also use the numeric keys to designate the resistance. Refer to **Numeric Keys** on page 27.

Note: A user can check the resistance (when it is not the chosen display) any time during a workout by lightly pressing either RESISTANCE ▼ or ▲ key for less than two seconds. Pressing the RESISTANCE ▼ or ▲ key for more than two seconds causes the resistance level to change.

AVERAGE SPEED: The estimated “mid-point” in linear speed at which the user is traveling even though the cycle is stationary. The displayed value relates to the total workout time divided by the total accumulated distance. The average speed only appears when a user selects it by pressing the appropriate CHANGE key.

CALORIES PER MINUTE: Indicates the approximate number of calories being burned per minute.

KEYS ON THE DISPLAY CONSOLE

The C846i has an easy-to-use keypad that is activated by the slightest touch. Remind users that they only need to apply gentle pressure to these keys.

Each key on the display console's keypad provides specific functions. Numeric keys (numbered 1, 2, 3,... through 0) let the user enter data in answer to the display prompts and change the program profile or resistance level during a workout. The standard keys, CHANGE, RESET, PROGRAM CHANGE ▲▼, QUICKSTART, RESISTANCE ▼▲, and ENTER, let the user enter data as well as control his or her workout.

The following information explains the different uses of the keys from left to right. To locate each key, look at the display console or refer to Diagram 12.

Diagram 12 C846i display console and keypad.

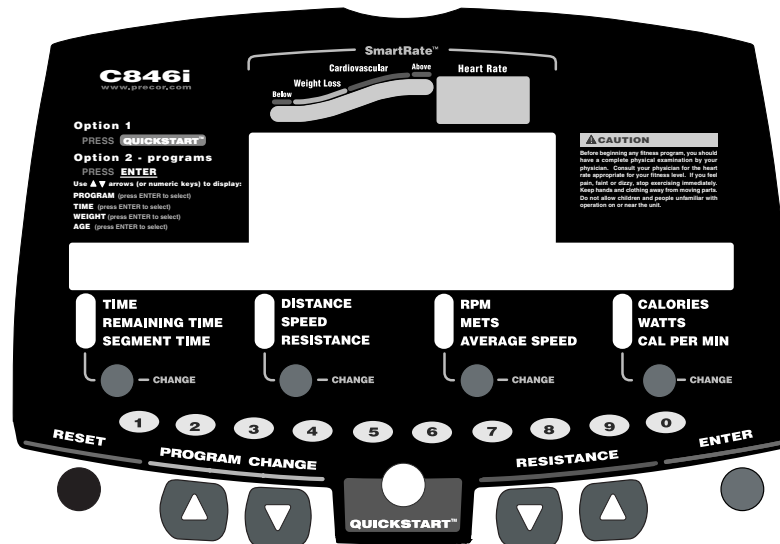

Keypad Tips

- If the optional power 2 adapter is not connected, the user needs to maintain a pedal speed above 20 revolutions per minute before keypad entries can occur. Refer to *Informational Displays Prior to Shutdown*.
- The setup prompts need to be answered using the numeric keys or by pressing the ▼ or ▲ keys. Accurate entries are required or features such as SmartRate will not work properly.
- Pressing ENTER selects the information being displayed.
- Pressing QUICKSTART bypasses further selections and prompts the user to exercise in Manual mode. Default values apply (Refer to QUICKSTART on page 28). The SmartRate display does not appear.
- Pressing RESET returns to the Precor banner.

Numeric Keys (0 - 9): During a workout, a user can press the numeric keys to change the resistance levels (1 to 25). Remember, if the numeric keys are used to alter the resistance, the user needs to designate, within three seconds, whether he or she is *increasing* (by pressing the RESISTANCE ▲ key) or *decreasing* (by pressing the RESISTANCE ▼ key), the corresponding resistance level.

Note: When the user presses the numeric keys to change the resistance, the actual setting appears on the display while the brake is being applied. If the user wishes to halt the change, the appropriate RESISTANCE ▼ or ▲ key must be pressed. The brake stops and the display shows the current level.

During the setup prompts, a user can also use the numeric keys to type in a program number (1 through 14), workout time, weight, and age. Note that he or she must press ENTER to process the selection.

CHANGE: During a workout, the CHANGE key lets a user choose which feature appears on the display.

RESET: While answering the setup prompts or during a workout, a user can cancel the program, clear the display, and return to the banner by pressing RESET.

PROGRAM CHANGE ▲▼: During a workout, the PROGRAM CHANGE ▲▼ keys let the user switch to a different program. When a user taps a PROGRAM CHANGE ▲▼ key, the program number and name appearing on the display corresponds to the current program selection. When a user presses and holds a PROGRAM CHANGE key for a few seconds, the program number and profile changes. The user can also choose a new program using the numeric keys. For more information, refer to *Selecting a New Program During a Workout*.

Important: *The PROGRAM CHANGE keys are disabled in the Weight Loss program and Fitness Test. If a user starts exercising and selects the Weight Loss program or the Fitness Test, he or she cannot change to another program. The opposite is also true. The C846i does not allow any mid-program changes to or from the Fitness Test or Weight Loss program.*

RESISTANCE ▼▲: During a workout, the RESISTANCE ▼▲ keys let the user decrease or increase the force applied against his or her pedaling. The display can show a range from 1 to 25. Setting 1 provides the least resistance.

When a user changes the resistance by pressing the RESISTANCE ▼ or ▲ key, the number that appears on the display shows the *target* resistance (not necessarily the present resistance being applied) because the display can change quicker than the brake application.

Another feature of the RESISTANCE ▼▲ keys lets the user review the C846i resistance any time during a workout. If RESISTANCE is not one of the chosen features being displayed, a user can view the actual resistance by lightly touching either RESISTANCE key. The user can opt to change the resistance if the key is held down or touched again within two seconds. Note that the numeric keys can also be used to adjust the resistance.

ENTER: Workout-specific prompts need to be answered and “entered” into memory. Pressing ENTER selects the information being displayed and processes it.

QUICKSTART: During the setup prompts, pressing QUICKSTART lets the user bypass further prompts and start a workout immediately using the Manual program. **Default values apply.**

Note: During a program change, pressing QUICKSTART starts the new program. Refer to *Selecting a New Program During a Workout*.

QUICKSTART Default Values	
Prompts	Default Value
1 Manual Program	Manual
Enter Time	Club limit. Note that the Weight Loss program is fixed at 28 minutes.
Enter Weight	150 lbs (68 kg)
Enter Age	0—A valid age must be entered to utilize the SmartRate display. If QUICKSTART is pressed <i>after</i> the Age prompt appears, then the SmartRate display will appear when the user grasps the touch-sensitive grips on the handlebar or wears the chest strap. If no age entry occurs, the SmartRate display lights up, but no blinking sensor appears.

The QUICKSTART key can be pressed any time during the setup prompts. Default values apply after that point. Refer to the table below.

Press QUICKSTART at the...

The following occurs:

- Precor banner The user bypasses the setup prompts and begins exercising in the Manual program.
- Program** prompt The displayed program is accessed.
- Time** prompt The time that appears on the display becomes the workout time limit. TIME may be set to any value from 1 to the Club limit. If “unlimited” workout time is allowed by the Club, a user can select it by entering 0 with the numeric key.
- Weight** prompt The weight that appears on the display becomes the designated weight that the C846i uses to compute statistics. Acceptable entries are between 1 and 999.
- Age** prompt The age that appears on the display becomes the designated age that the C846i uses to compute statistics. A correct age entry between 1 and 99 is very important if the user plans to use the heart rate features of the C846i. The QUICKSTART key acts the same as the ENTER key at this point because the user has answered all the setup prompts.

Exercising on the C846i

Once the C846i is assembled, it is ready to use. The easy-to-understand prompts let the user select a program and specify how long he or she wants to exercise.

Club owner's and managers note: This section of the manual is written for the user because it specifically explains how to exercise on the cycle. References are made in second person.

ADJUSTING THE SEAT

Before starting a workout, you should position the seat properly to avoid strain on your knees. To check for proper seat position, sit on the seat. Place your feet on the pedals. Your extended leg should be slightly bent at the knee in a 10 to 15 degree angle.

If you need to adjust the seat, the C846i Upright and C846i Recumbent have different seat adjustment instructions. Refer to the instructions below for your particular unit.

Note: You can adjust the tilt on the seat if needed. Refer to *Adjusting the Seat Tilt*.

Diagram 13 *Adjusting the seat.*

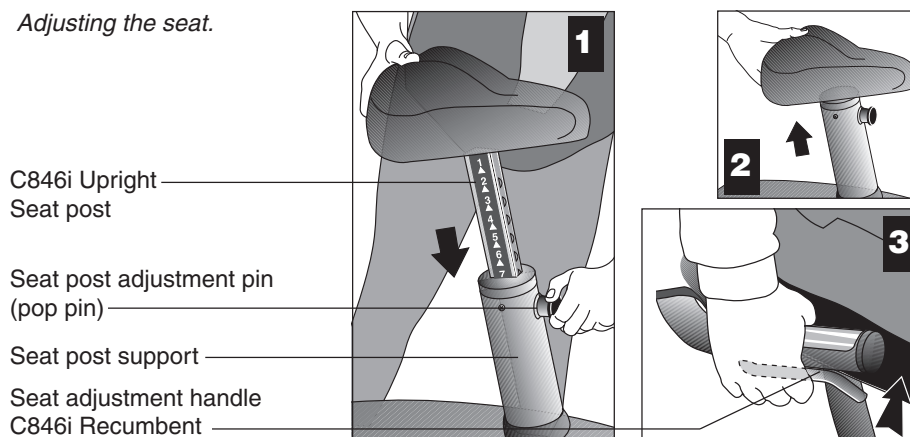

C846i Upright Seat Adjustment

1. Dismount and hold the post underneath the seat with one hand while you pull out the seat post adjustment pin (pop pin) with the other hand. Refer to Diagram 13, #1.
2. Slide the seat post up or down into the desired position, and then release the seat post adjustment pin. Before sitting on the cycle, press down firmly on the seat to make sure that it does not slip and that it is secured.

Note: If you only plan to raise the seat, you can do so without pulling out the seat post adjustment pin. Refer to Diagram 13, #2.

C846i Recumbent Seat Adjustment

1. Sit on the seat with your feet in the pedals. Pull the seat adjustment handle up while you bend your knees and slide the seat forward or backward along the seat rail (Diagram 13, #3). Align the seat with one of the marks on the seat rail and release the handle.
2. Before continuing with your workout, sit in the seat and try to slide the seat along the rail. Make sure that it does not slip and that it is secured.

USING THE HEART RATE “TOUCH” CAPABILITY

If you wish to view your heart rate on the display, you must grasp **both** touch-sensitive grips on the handlebars while exercising. Refer to Diagram 14.

Diagram 14 *Hand placement on the handrail grips.*

Heart rate grip
C846i Recumbent

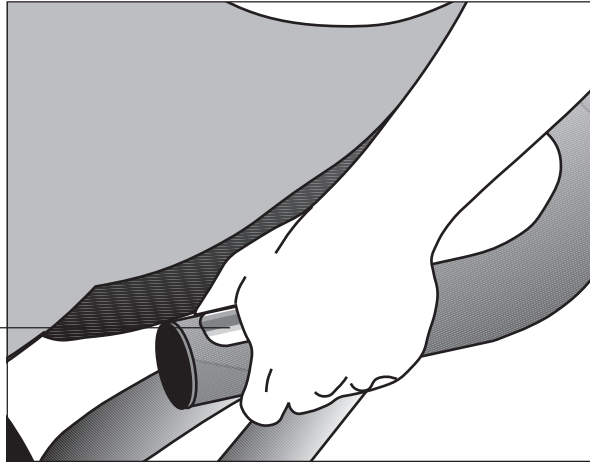

A heart rate signal is transmitted to the receiver installed in the display console. During a workout, the heart rate indicator lights, begins blinking, and then displays the heart rate. This lets you see what your heart rate is doing even when the display is presenting other workout statistics. For more information, refer to the *Heart Rate Feature and Target Zones*.

WORKOUT TIPS

The steps to exercising on the C846i are listed on the opposite page. A short explanation appears on the left with the more thorough description following on the right. Tips to consider during a workout are shown below.

CAUTION: Before beginning any fitness program, make sure that you receive a complete physical examination from your physician.

- Maintain a pedal speed above 20 RPM.
- Answer the setup prompts using the numeric keys or by pressing the ▼ or ▲ keys.
- Press ENTER to select the information being displayed.
- QUICKSTART bypasses further selections. Default values apply (refer to QUICKSTART on page 28). SmartRate is not active.
- Refer to *Keypad Tips* on page 26 for additional information.

QUICK STEPS TO EXERCISING

Important: If BATTERY LOW appears on the display anytime during a workout, contact the club personnel. Pay attention to the words, PEDAL FASTER. The C846i is warning you that you need to pedal faster to avoid disconnecting the battery, which is the power source for the C846i display.

- 1 **Put on the chest strap.**
(Available with the Precor Heart Rate Option.)
 1. For your heart rate to appear on the display, you need to wear a chest strap or hold onto the grips on the handlebars.
- 2 **Adjust seat, sit down, and begin pedaling.**
 2. Begin pedaling. Once the Precor banner appears, press ENTER.
- 3 **Select a program. Answer the setup prompts.**
 3. Follow the display prompts. Make a program selection and enter your workout time, weight, and age.

Note: To answer the setup prompts, use the numeric or ▼▲ keys. Press ENTER to select the information being displayed. The fourteen available programs appear on the label attached to the display console. Brief program descriptions are also provided beginning on page 38.

Important: Any time during the setup prompts, you can press the QUICKSTART key. Refer to QUICKSTART on page 28.
- 4 **Begin exercising.**
Continue pedaling. Adjust resistance by touching RESISTANCE ▼ or ▲.

Pause

 4. After setting up the parameters of your workout session, continue pedaling throughout the program. Resistance level settings can be changed using the arrow keys. A different program can be selected using the PROGRAM CHANGE keys.

To pause during your workout session, stop pedaling for a few seconds. Be aware that if the optional power adapter is not attached, you have only thirty seconds before the C846i shuts off. Refer to *Pause, Cool Down, and Exit Features*.
- 5 **Complete the program and cool down.**
 5. When you have completed a program that has a limited duration, a five-minute cool-down period automatically begins.

Note: During cool down, if you wish to continue exercising, touch a PROGRAM CHANGE ▲▼ key and select a new program. Your workout statistics carry forward to the new program.
- 6 **Continue pedaling while reviewing the final workout statistics.**
 6. When the cool-down period ends, the WORKOUT SUMMARY appears. If you wore a chest strap or held onto the handlebar grips during your workout, a heart rate analysis follows the banner and displays:
 - The average heart rate during your workout
 - The maximum heart rate during your workout
 - The duration that your heart rate was in the weight loss or cardiovascular zone

Workout statistics except TIME, DISTANCE, and CALORIES reset to zero. (TIME shows the accumulated workout time including warm-up and cool-down periods.)
- 7 **Stop pedaling.**
 7. Stop pedaling to end your workout.

COOLING DOWN AFTER A WORKOUT

Cooling down is an important aspect of your workout because it helps reduce muscle stiffness and soreness by transporting excess lactic acid out of the working muscles. Cooling down for at least three minutes helps provide a smooth transition that allows your heart rate to return to its normal (non-exercising) state. The C846i automatically initiates a five-minute cool-down period once you complete a program that has a specified time duration. A prompt appears, indicating that you are in cool down.

During your cool down, the workout statistics continue to appear. The **Time** display shows the accumulated time which includes warm-up and cool-down periods. When you complete the five-minute cool down, a WORKOUT SUMMARY appears. Refer to the information below.

***Important:** To activate a cool-down period, a program must “end.” The program ends when the workout time (entered during the setup prompts) expires. If no workout time entry occurred or the time entered was zero, then (from a software perspective) no time limit exists, so a cool-down period is not appended to the program. (Note that club time limits do apply whether or not a workout time was entered.)*

PAUSE, COOL DOWN, AND EXIT FEATURES

Pausing, cooling down, and exiting are integral parts of your workout. The C846i goes through several prerequisites before actually exiting a program. The following tables explain the various situations. Since the C846i is self-powered, pedal movement must be continuous to avoid shutdown mode. For more information, refer to *Informational Displays Prior to Shutdown*.

Note: If the optional power adapter is supplying power to the C846i, the factory setting for Pause mode is two minutes (120 seconds). The club has the option to change the setting. A duration can be set between 1 and 120 seconds and limits how long a user can pause his or her workout. Refer to *Setting a Pause Time Limit*.

In a program		This is what happens...
If you complete it		Enter Cool-down mode. At the start of the cool-down period, the resistance is reduced by 20 percent. You can adjust the setting using the numeric or RESISTANCE ▼▲ keys. The display features remain, so you can review your workout statistics. Note: A cool-down period is appended to those programs that have a finite duration. If you do not enter a workout time during the setup prompts, or the club has set “no limit” as the default duration, then a cool-down period does not occur when you reach the end of a program.
If you press RESET		Enter the WORKOUT SUMMARY mode. You can scan through the workout statistics by pressing the CHANGE key. Note that the Time display shows the accumulated workout time including warm-up and cool-down periods.
If no pedaling or slow pedaling is detected		Enter Pause mode. PEDAL FASTER appears on the display and TIME stops accruing. Refer to page 23.
In Pause mode		This is what happens...
If you resume pedaling		Returns to the program and the workout statistics continue from where you left off.
If you press RESET		Exits the program and returns to the banner or blank display.
If you exceed time limit		The C846i exits Pause mode, resets the displays, and shuts off.
In Cool-down mode		This is what happens...
If no pedaling or slow pedaling is detected		Enter Cool-down, Pause mode. TIME stops accruing and PEDAL FASTER appears on the display. If you enter Pause mode, it is of limited duration. Check with club personnel or refer to <i>Club Information</i> and <i>Informational Displays Prior to Shutdown</i> .
resume pedaling		Returns to Cool-down mode.
you press RESET		Displays the WORKOUT SUMMARY banner. See RESET above.
it ends.		Displays the WORKOUT SUMMARY banner.
At the WORKOUT SUMMARY banner		This is what happens...
If you press RESET		The workout statistics are reset to zero and, if you continue pedaling, the Precor banner appears on the display.

SELECTING A NEW PROGRAM DURING A WORKOUT

While cooling down or exercising on the C846i, you can change to a different program (except the Weight Loss program or the Fitness Test) by touching the PROGRAM CHANGE keys.

Note: Continue pedaling and keep the RPM above 20 while you adjust to your new selection.

To change to a new program during your workout, take the following steps:

1. Press a PROGRAM CHANGE ▲ or ▼ key. The display briefly indicates the program that is currently running. You can continue to press either ▲ or ▼ key to display a different program.

Note: While selecting a new program, your workout is momentarily suspended and the LEDs next to the workout statistics are not lit. If the QUICKSTART or ENTER key is not pressed within 5 seconds, then the C846i resumes your workout without making any program changes.

2. While the new program selection appears on the display, you have two options: press QUICKSTART or press ENTER.

Option 1: Press QUICKSTART if you wish to continue your workout without any further prompts appearing on the display. All the aspects from the previous program (workout time, statistics, weight, age, etc.) are carried forward. SmartRate will be active as long as it appeared during your initial workout. The workout time may be limited per the overall club time limit.

Option 2: Press ENTER if you wish to continue your workout, but want to add aspects that may not have been part of your initial program such as weight and age. The C846i reacts as if you are starting a new workout and setup prompts appear requesting information. Once the setup prompts are answered, workout statistics from the previous program are carried forward. If your age is entered, SmartRate will be active. As with QUICKSTART, the workout time may be limited per the overall club time limit. Refer to *Club Information*.

Once the user reaches the club time limit in the second program selection, the PROGRAM CHANGE keys are disabled. Note that users cannot use the PROGRAM CHANGE keys to select a different program if one minute or less remains before the club time limit expires.

Programs

The C846i lets the user choose between fourteen variable programs. This section provides information about the special features and functions of the C846i programs and how to best utilize the:

- Heart Rate and SmartRate features
- Manual program
- Cross Country program
- Hill Climb program
- Random program
- Interval programs (3)
- Watts Control program
- Heart Rate Control program
- Weight Loss program
- Resistance Custom program
- Distance Goal program
- Calorie Goal program
- Fitness Test

PROGRAM FEATURES

- If the club allows it, you can exercise indefinitely in any program (except Weight Loss). At the **Time** prompt, select INFINITE by pressing the zero on the numeric keypad.

Important: *The automatic cool-down period is not appended to programs where the duration is INFINITE.*

- Place a time limit on any program during the setup prompts. At the workout **Time** prompt, indicate the duration of your workout. When you complete the program, the automatic cool-down period begins.
- Determine the pedal resistance as you move through the program.
- SELECT programs that provide preset resistance levels. In several programs, the resistance levels automatically change as you progress through the program profile. You can override the resistance using the RESISTANCE ▲ or ▼ keys for each upcoming column in the program profile. The profile changes accordingly and the resistance position is saved until a different program is used. When you complete a program with a time limit, the automatic cool-down period begins.
- The progress that you make during a program is tracked by a blinking cursor. If the column is several segments high, the entire column blinks.
- Access heart rate and SmartRate capabilities when the user wears a chest strap or holds onto the handlebar grips during a workout. Note that the SmartRate indicator lights do not appear if QUICKSTART is pressed at the Precor banner.

The different program names appear on the following pages along with a description of the program features. Refer to Diagram 16.

THE HEART RATE FEATURE AND TARGET ZONES

To use the heart rate features, you must wear a chest strap or grasp both grips on the handlebars while exercising. A transmitter sends your heart rate signal to the receiver installed in the display console. The signal appears as your pulse rate on the display. During your workout, the heart rate indicator lights, begins blinking, and then displays your heart rate. This lets you see what your heart rate is doing even when the display is presenting other workout statistics.

Diagram 15
Target Zones.

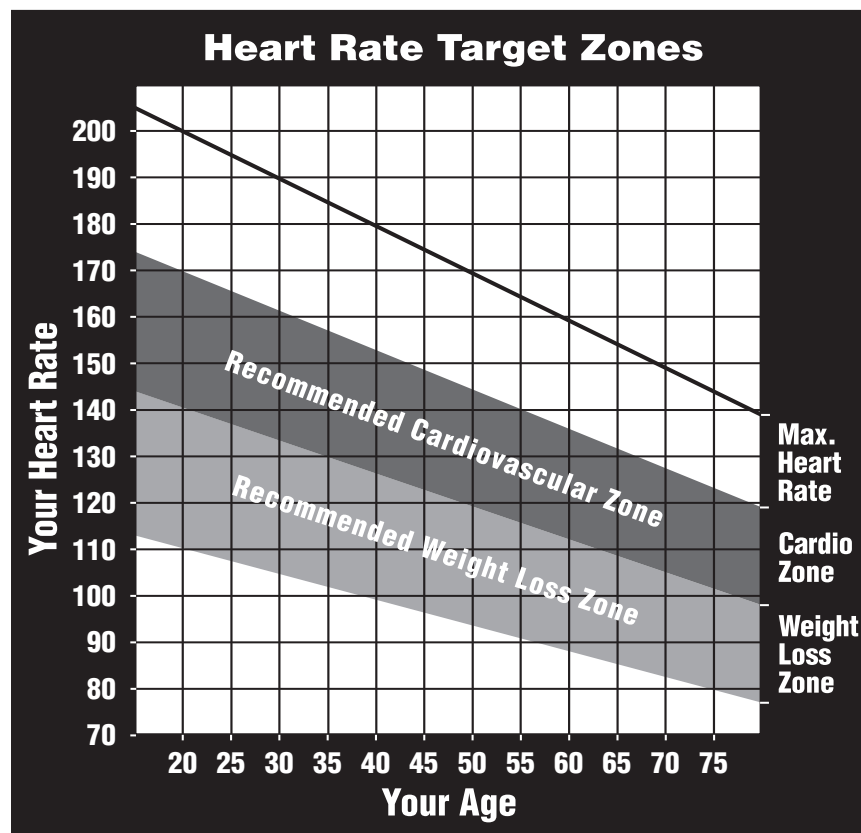

Diagram 15 illustrates the ideal target zones for your age. Use the chart as a guideline. Always check with your physician and verify what your appropriate heart rate target zone should be for your age, height, weight, and physical fitness.

Note: The SmartRate display does not appear if you use the QUICKSTART key to access a program. Refer to QUICKSTART on page 28.

Important: The chest strap is optional equipment and can be purchased through your dealer. The grips on the handlebars are factory installed.

THE SMARTRATE FEATURE

Add the benefit of SmartRate to every program on the C846i. Using SmartRate as a visual cue helps you adjust your exercise routine to suit specific needs. SmartRate simplifies the correlation between heart rate and exercise. You do not have to stop concentrating on your workout to find your pulse. It is displayed right in front of you along with the SmartRate zone. Once you begin a program, a blinking segment in the bar graph appears on the left of the display (if you entered your age during the setup prompts). The blinking segment indicates the zone that your heart rate is in: weight loss or cardiovascular.

Important: Access to SmartRate is only available when the person exercising wears a chest strap or uses the grips on the handlebars. (The chest strap is a separate purchase option.) The SmartRate indicator lights do not appear when QUICKSTART is used to select a program.

However, if SmartRate is active during your workout then it remains active even though your program selection may change. For example, during a workout you decide to select another program by touching the PROGRAM CHANGE ▲▼ keys. You press QUICKSTART (instead of ENTER) to continue your workout in the new program. If SmartRate was active during the initial program selection, it continues to appear on the display.

Weight Loss Zone

For the ideal “weight loss” range, your heart rate should be between 55% and 70% of your maximum aerobic heart rate. It should never exceed 85% of your maximum aerobic heart rate or go above your training zone. Refer to Diagram 15 for your appropriate target zone.

Cardiovascular Zone

When you maintain your heart rate between 70% and 85% of your maximum aerobic heart rate, you are improving your overall cardiovascular/ cardiorespiratory fitness level. Maintaining your heart rate in either zone (weight loss or cardiovascular) for 30 minutes or more on a regular basis (minimum three times a week) provides the greatest benefits.

Diagram 16 C846i programs.



MANUAL MODE AND THE QUICKSTART KEY

Manual mode lets you set the resistance level. As with other programs, when you complete the time limit set for the program, the automatic cool-down period begins.

Note: If a user is allowed to choose “INFINITE,” then no time limit is set and no automatic cool-down period exists.

You can choose Manual mode in two different ways:

- Pressing the QUICKSTART key at the Precor banner. QUICKSTART bypasses the remaining selections and starts the Manual program. Default values includes the club’s time limit, a weight value of 150 lbs (68 kg), and an age of 0. The SmartRate display is inactive.
- Pressing ENTER at the Precor banner. This causes the C846i to display several setup prompts. When #1 — **Manual Time Goal** appears on the display, press ENTER.

The Manual program profile initially appears as a flat line. Use the RESISTANCE ▼▲ keys or the numeric keys to adjust the resistance level. As you proceed with your workout, a blinking column represents your position on the program.

CROSS COUNTRY AND HILL CLIMB PROGRAMS

The Cross Country and Hill Climb programs consist of alternating columns of preset resistance levels. The program profile is divided into columns. The height of each column reflects the changes in resistance levels. Though the resistance is preprogrammed, you can override it during the program, by pressing a RESISTANCE ▲ or ▼ key.

RANDOM PROGRAM

Every time a Random program is selected, a different program profile appears. The columns that appear in the program profile maintain a set resistance that you can override using the RESISTANCE ▼▲ keys. The resistance is preset to 1 for the first column. The maximum change allowed between columns is plus or minus 4 resistance levels. If the club lets you set the workout time at INFINITE (number zero on the numeric keypad), you need to incorporate a cool-down period into your workout.

INTERVAL PROGRAM

The Interval program is one of the best for conditioning your cardiovascular system. The program is designed to raise and lower your heart rate in a repeating fashion for a specified period of time. The three interval programs on the C846i let you select the rest and work intervals according to your training regimen. In the 1–3 interval program, each 1-minute rest interval is followed by a 3-minute work interval. In the 1–2 interval program, each 1-minute rest interval is followed by a 2-minute work interval. In the 1–1 interval program, each 1-minute rest interval is followed by a 1-minute work interval.

The resistance levels are preset at 1 for the rest interval and 3 for the work interval. At any point during the workout, you can change the settings of the current interval by simply pressing the RESISTANCE ▼▲ or number keys. The software remembers the new settings and applies it to the appropriate rest or work interval throughout the remainder of the program.

Each time the C846i changes intervals, it informs you by displaying a message. When you complete the time limit set for the program, the automatic cool-down period begins.

Important: *If you entered your age during the setup prompts and wear the chest strap or utilize the heart rate grips, you can adjust the rest or work intervals to keep your heart rate in its recommended zone. For the weight loss mode, try to maintain your heart rate at the lower end (55% of maximum heart rate) while in the “rest” intervals and keep it at 70% of maximum heart rate while in the “work” intervals. Refer to Diagram 15.*

WATTS CONTROL PROGRAM

On the C846i, watts indicates the amount of energy the C846i is currently generating and is derived from the current resistance and pedaling speed. The Watts Control program affects the user in that it keeps the level (as measured in watts) of the user's expenditure in energy fixed or constant. When a user selects the Watts Control program, an initial target of 50 watts is preset. As the user pedals, the pedal resistance changes to keep the energy expenditure stable at a constant 50 watts. The faster the user pedals (higher RPM), the lower the resistance. If a user pedals slowly, a higher pedal resistance occurs.

A user can change the watts level by touching the RESISTANCE ▼▲ keys or pressing the numeric keys followed by the appropriate ▼ or ▲ RESISTANCE key.

HEART RATE CONTROL PROGRAM

Once you complete the warm-up period and achieve your target heart rate, the Heart Rate Control Program monitors your heart rate and automatically maintains it within a few beats per minute (bpm) of the selected target. Lights on the SmartRate bar graph appear to show the zone that you are in.

Note: For the C846i to detect a heart rate, you must grasp the handlebar grips or wear the chest strap during a workout.

The handlebar grips or chest strap transmits your heart rate signal to the receiver that is installed in the display console. During your workout, the heart rate indicator lights which lets you see what your heart rate is doing even when the display is presenting other workout statistics.

To use the Heart Rate Control program, follow the steps found in *Quick Steps to Exercising* and choose **#9 — Heart Rate Control** as the program.

Note: If your heart rate moves into the heart rate zone for your age during the three-minute warm-up period, the warm-up period ends and the Heart Rate Control program begins.

CAUTION: A warning message will appear if you go above your maximum recommended heart rate target zone. Heed the warning and get permission from your personal physician before exercising above the maximum recommended zone for your age and fitness level. Refer to Diagram 15 for the recommended target zones.

WEIGHT LOSS PROGRAM

The Weight Loss program incorporates the latest findings on fat-burning and weight loss through exercise. It is based on research at the world-renowned Cooper Institute for Aerobics Research and it is designed to help you burn the most fat during a 28-minute workout, while minimizing the risk of discomfort and injury. The Weight Loss program is similar to the Interval program, but the intervals are set at four minutes. If you use the heart rate grips on the handlebar or wear the chest strap, try to keep the rest interval's target heart rate at 55% of maximum aerobic heart rate, while the work interval should be set to 70% of maximum aerobic heart rate. As in the Interval program, once you set the resistance levels for the first rest and work interval, the C846i automatically repeats the interval settings throughout the program.

Note: When you complete the 28-minute time limit set for the program, the automatic cool-down period begins.

RESISTANCE CUSTOM PROGRAM

A custom program is available on the C846i where the resistance is preset by the club. Though the resistance is preset, a user can adjust the settings during a workout by touching the RESISTANCE ▼▲ keys. Once the program ends, it reverts back to the custom resistance levels set by the club. Refer to *Limiting the Resistance Range* and *Customizing a Program*.

GOAL-BASED PROGRAMS

These C846i programs (Distance Goal and Calorie Goal) are similar to the Manual program except that the user's position and program duration are based on a "distance" or "calorie" goal. You can use the numeric keys or the RESISTANCE ▼▲ keys any time during the program to change the resistance. When you complete the goal set for the program, the automatic cool-down period begins.

Note: A club time limit may exist for these programs. A prompt appears on the display if the club time limit is reached before the goal. Refer to *Club Information*.

FITNESS TEST

The Fitness Test (program number 14) provides a means of determining your fitness score. The algorithm used to create this program was developed by Dr. Neil Gordon of the Cooper Clinic.

The Fitness Test determines heart rate response to varying levels of exercise. It measures the maximum amount of oxygen the body can use for energy production during exercise. The higher the amount of oxygen that your body can use, the greater your ability to exercise for prolonged periods of time. You can use the results of the Fitness Test to personalize a weight loss fitness regimen to meet your needs.

Fitness Test Guidelines

Before selecting the Fitness Test, read the following guidelines:

- Sit and rest for at least five minutes prior to taking the test. This brings your heart rate to a resting state.
- You must wear the chest strap and complete at least two of the six stages of the test before a fitness score can be achieved and presented.
- The fitness score is affected by your weight and age. Be sure to include this data during the setup prompts.
- Let the test adjust the pedal resistance for you. However, if you need to stop pedaling to regain control or reduce your heart rate, please do so — you can retake the Fitness Test later.
- The RESISTANCE ▼▲ keys are disabled during the test.
- The number of two-minute stages that you complete is determined by the cycle's software and is dependent on your level of fitness. Do not be alarmed if you do not complete all six stages; this is normal. However, you must complete at least two stages to receive a fitness score.
- When you finish the Fitness Test, the pedal resistance is reduced. No automatic cool-down period is appended to the test.
- Create your own cool-down period by pressing the RESISTANCE ▼▲ keys to regulate the brake and return your heart rate to a normal, restful state.

The Fitness Test ends if any one of the following occurs:

- You stop pedaling.
- Your heart rate rises and remains for one-minute above the maximum allowable heart rate (220 minus your age). Refer to Diagram 15.
- Your heart rate increases during the first stage and climbs above 85% of the maximum allowable heart rate (220 minus your age). Refer to Diagram 15.
- Your heart rate remains at or above 80% of the maximum allowable heart rate (220 minus your age) in any subsequent stages.
- Your heart rate cannot be detected or is no longer being transmitted.
- You complete all six stages of the test.

Fitness Test Scores

When a valid score is obtained it appears in the display. Tables 1 and 2 show the desired range in fitness levels depending on your age and gender.

Note: The score is also stored for future retrieval. It appears on the display when the Fitness Test is selected as your desired program.

Cardiovascular Fitness Score Category — Females

Age in Years	Low Fitness	Medium Fitness	High Fitness
20 - 39	28 (or below)	28 - 33	33 (or above)
40 - 49	26 (or below)	26 - 31	31 (or above)
50 - 59	24 (or below)	24 - 28	28 (or above)
60 and over	22 (or below)	22 - 26	26 (or above)

Cardiovascular Fitness Score Category — Males

Age in Years	Low Fitness	Medium Fitness	High Fitness
20 - 39	35 (or below)	35 - 42	42 (or above)
40 - 49	32 (or below)	32 - 39	39 (or above)
50 - 59	29 (or below)	29 - 36	36 (or above)
60 and over	24 (or below)	24 - 31	31 (or above)

Values in Tables 1 and 2 are based on the findings of the Aerobics Center Longitudinal Study, an eight-year study involving over 13,000 female and male participants.

Maintenance

The self-powered C846i will continue to run smoothly and efficiently as long as you maintain it. You are responsible for cleaning and maintaining the unit's integrity. If you fail to maintain the C846i as described below, it could affect or void the Precor Limited Warranty.

DANGER — To reduce the risk of electrical shock, always unplug the C846i from the optional power adapter before cleaning or performing any maintenance tasks.

INSPECTION

Perform a daily inspection of the unit. Look and listen for loose fasteners, unusual noises, and any other indications that the equipment may be in need of service. Obtain service should you notice any of the above.

***Important:** If you determine that the C846i is in need of service, move it away from the main workout area and place a large "Out of Service" sign on it.*

To order parts or to contact a Precor authorized service provider in your area, refer to *Obtaining Service*.

CLEANING THE EQUIPMENT

Most of the working mechanisms are protected inside the casing. However, for efficient operation, the C846i relies on low friction. To keep the friction low, the C846i pedals and internal mechanisms must be as clean as possible.

- To clean all exposed surfaces on the C846i, it is recommended that you use a diluted solution of mild soap. Clean the C846i everyday with a soft cloth, dampened (not dripping wet) in the solution.

CAUTION: Do not use any acidic cleaners. Doing so will weaken the unit's coating and void the Precor Limited Warranty. Never pour water or spray liquids on any part of the C846i. Allow the C846i to dry completely before using.

- Periodically, clean the grooves on the foot pedals using a soft nylon scrub brush. Vacuum the floor underneath the unit to prevent the accumulation of dust and dirt.
- The Precor Heart Rate equipment requires little maintenance beyond keeping it dust free. Dampen a sponge or soft cloth in mild soap and water to wipe the touch-sensitive grips on the handlebar or to clean the chest strap. Dry the surface thoroughly with a clean towel.

STORING THE CHEST STRAP

Store the chest strap in a place where dust and dirt cannot accumulate on it, such as a closet or drawer. Be sure to keep the chest strap protected from extremes in temperature. Do not store it in an area that may be exposed to temperatures below 32 degrees Fahrenheit.

ADJUSTING THE SEAT TILT

You can adjust the seat tilt by taking the following steps:

1. Loosen the nut beneath the seat using a 17 mm ($1\frac{1}{16}$ -inch) box-end wrench or crescent wrench. Refer to Diagram 17.

Diagram 17 *Loosen nut to adjust seat tilt.*

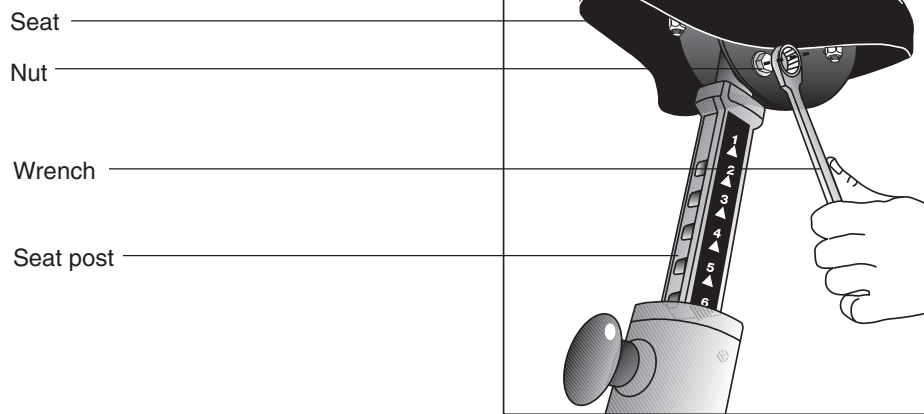

2. Adjust the seat's tilt (forward or back). Refer to Diagram 18.
3. Wrench tighten the nut.
4. Apply pressure to the seat to make sure that it does not move. Readjust and retighten the nut, if necessary.

Diagram 18 *Tilt the seat forward or backward.*

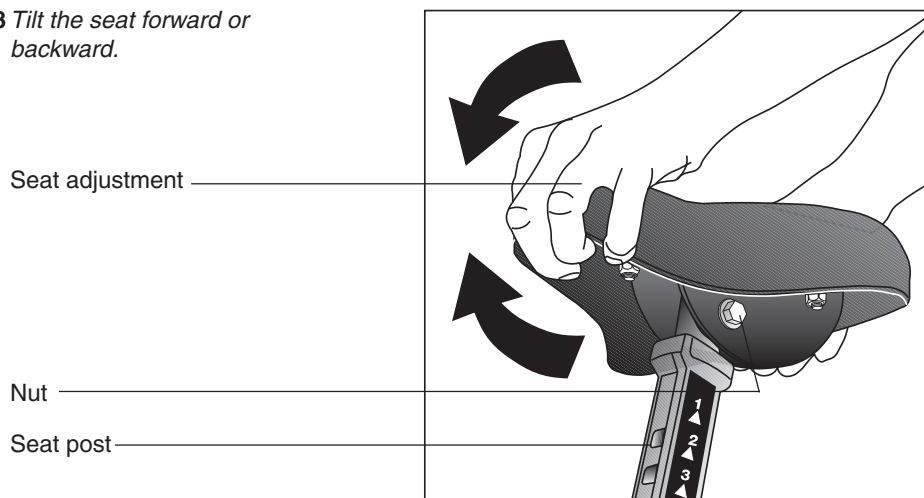

ADJUSTING THE SEAT'S SIDE-TO-SIDE MOVEMENT ON THE C846i RECUMBENT

Periodically check the seat on the C846i Recumbent. Take the following steps to eliminate any side-to-side rocking movement:

1. To determine if the seat rocks side to side, straddle the base with your feet firmly planted on the floor.
2. Sit on the seat and face the display console. Gently, move your upper body side to side. If the seat rocks side to side with you, you need to "realign" the center wheels that run underneath the seat. Adjustment bolts are located on the sides of the seat rail.

To realign the seat's center wheels, take the following steps:

1. Obtain a $\frac{3}{16}$ -inch and $\frac{5}{16}$ -inch hex key.

Diagram 19 *Adjusting the wheel locks.*

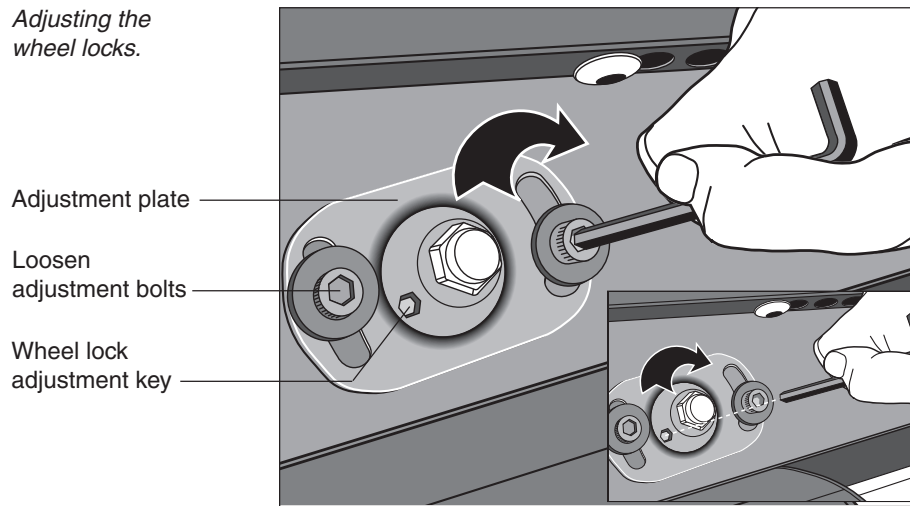

2. Start on one side of the cycle and loosen the two adjustment bolts with the $\frac{3}{16}$ -inch hex key as shown in Diagram 19.
3. Using the $\frac{5}{16}$ -inch hex key, turn the wheel lock adjustment key *clockwise* $\frac{1}{4}$ turn. This thrusts the center wheel up inside the top rail. Continue holding the hex key in place while you tighten the adjustment bolts with the $\frac{3}{16}$ -inch hex key.
4. Remove the hex keys and perform step 3 on the opposite side of the seat.
5. Check that the seat no longer rocks from side to side. If rocking movement continues, you may need to repeat the process.

USING THE OPTIONAL POWER ADAPTER

If you choose to purchase the optional power adapter, you must also purchase the internal cable kit. This kit supplies a cable, bracket, and fasteners that allow the power adapter to connect to the lower electronics board.

CAUTION: The internal cable kit requires installation by an authorized service person. Do not attempt installation on your own as you could void the Precor Limited Warranty. If you need assistance, please refer to *Obtaining Service*.

You can use the C846i while the power adapter is plugged in. The display functions a bit differently when the power adapter is used. It returns to the Precor banner instead of appearing blank when a user stops exercising.

If no one has used the C846i for an extended period of time, the battery may need recharging. Refer to *Informational Displays Prior to Shutdown*. Symptoms of a low battery include:

- A flickering or erratic display
- No workout statistics appear or accumulate
- Changes to the resistance are ignored

Diagram 20 *Plugging in the optional power adapter.*

Receptacle location

Power adapter plug

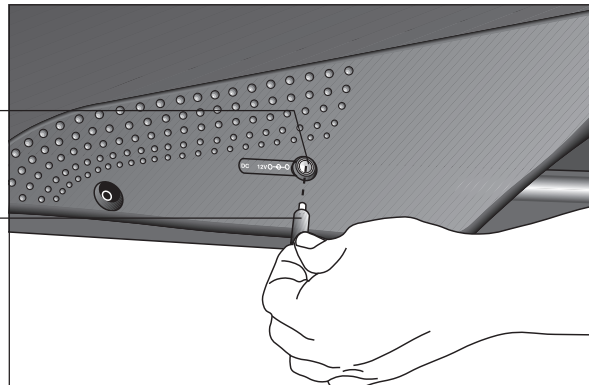

Diagram 20 shows the receptacle for the optional power adapter. Plug the opposite end into the appropriate power source for your unit (110/120v or 220/240v).

When the optional power adapter is in use, ensure that the power supply cord does not create a safety hazard by keeping it out of the way of traffic and moving parts. If the power supply cord or power adapter is damaged, it should be replaced.

When the C846i is *not* in use, ensure that the optional power adapter is unplugged from the wall outlet and is positioned so that it will not become damaged or interfere with other equipment or people. Ensure that it is kept free from dirt, moisture, or damage.

SERVICING THE C846I AND LONG TERM STORAGE

Do not attempt to service the C846i yourself except for the maintenance tasks described in this manual. The unit does not contain any user-serviceable parts that require lubrication. For information, refer to *Obtaining Service*.

HEART RATE TROUBLESHOOTING TIPS

A few easy steps can be taken before you need to call Customer Support regarding heart rate problems. One of the first things to do is verify the following:

- A chest strap is being worn properly by the user during a workout. Or, the user is placing both hands on metal grips found on the handlebars.
- The user is pedaling above 20 RPM.
- The user is exercising in a selected a program. (The Heart Rate feature is activated when a program profile appears.) Note that if the user presses QUICKSTART to access a program, the SmartRate and heart rate features will not appear.

It may take several seconds for the heart rate receiver to detect a number of *valid* heartbeats. Once it does, the user's heart rate is displayed when the Heart Rate indicator (LED) is lit during the scanning process.

If three dashes (— — —) appear when the Heart Rate indicator (LED) is lit and all the previously discussed steps have been taken, then you need to do the following:

Touch-sensitive heart rate grips

- To conduct electrical impulses from a user's heart, both touch-sensitive grips (metal strips) must be in contact with the user's skin. Usually, the concentration of salts in a person's perspiration provides enough conductivity to transmit a signal to the receiver in the display console. However some people, because of body chemistry or erratic heartbeats, cannot use the heart rate touch-sensitive grips on the C846i. A chest strap may provide better results. Refer to *Obtaining Service*.

Chest strap

- Make sure that the electrodes on the chest strap are moist and placed properly against the skin. Sometimes, due to body chemistry, the chest strap cannot successfully detect and transmit a heart rate. If this occurs, dampen the back of the chest strap and then check to be sure that the strap is comfortably tight around the chest and centered in the middle of the user's chest.
- Another possibility which can cause erratic readings is that the chest strap's battery may be dead. To purchase a new chest strap, refer to *Obtaining Service*.

C O M M E R C I A L P R O D U C T S D I V I S I O N

Thank You and Welcome to Precor



We are confident that you will be pleased with your purchase and that your new Precor equipment will help satisfy your customers' fitness needs, while helping you meet your business goals.

To allow us to serve you better, please take a few moments to complete and return your warranty registration.

YOU MAY ALSO REGISTER ONLINE AT

www.precor.com/warranty

If you have questions or need additional information, contact your local dealer or call Precor Customer Support at 800-347-4404.

Fold along dotted line and tape closed prior to mailing.

COMM.

PRECOR USA
Precor Incorporated
20031 142nd Avenue NE
PO Box 7202
Woodinville, WA 98072-4002

PLACE
STAMP
HERE

Commercial Equipment Limited Warranty

PLEASE READ THESE WARRANTY TERMS AND CONDITIONS CAREFULLY BEFORE USING YOUR PRECOR INCORPORATED PRODUCT. BY USING THE EQUIPMENT, YOU ARE CONSENTING TO BE BOUND BY THE FOLLOWING WARRANTY TERMS AND CONDITIONS.

Limited Warranty.

Precor Incorporated warrants all new Precor products to be free from defects in materials and manufacture for the warranty periods set forth below. The warranty periods commence on the invoice date of the original purchase. This warranty applies only against defects discovered within the warranty period and extends only to the original purchaser of the product. Parts repaired or replaced under the terms of this warranty will be warranted for the remainder of the original warranty period only. To claim under this warranty, the buyer must notify Precor or your authorized Precor dealer within 30 days after the date of discovery of any nonconformity and make the affected product available for inspection by Precor or its service representative. Precor's obligations under this warranty are limited as set forth below.

Warranty Periods and Coverage.

Commercial Cardiovascular Products, also known as C-Series Products, (excluding StretchTrainer, Strength Products).

- Seven years frame, five years touch sensor display housing, two years parts, one year labor.
- For treadmills, five years motor fan, three years drive motor.
- For self-powered ellipticals and bikes, one year battery.
- For InSite, one year parts and labor.
- Labor coverage for options as defined below.

StretchTrainer

Five years frame, two years parts, 90 days upholstery, no labor.

Strength Products (S3.45 and S3.25 only)

Ten years frame; three years bearings, guide rods, cams, pulleys; one year belts, cables, hand grips, miscellaneous parts; 90 days upholstery; no labor.

Options / Accessories / Battery-powered or Self-Operated Devices

Many options or accessories have components that are connected internally or mounted inside the electronic console. The following guidelines determine the warranty for these components. If the internal components are installed by the factory or by an authorized dealer as part of the original sale and delivery, they have a warranty that is identical to the warranty of the equipment in which they are connected or mounted. If the internal components are not installed by the factory or by an authorized dealer as part of the original sale and delivery, they have a 90 days parts and labor limited warranty. All components that are not internally connected have a 90 days parts only limited warranty. Satisfactory proof of purchase is required in all cases.

Conditions and Restrictions.

This warranty is valid only in accordance with the conditions set forth below:

1. The warranty applies to the Precor product only while
 - a. it remains in the possession of the original purchaser and proof of purchase is demonstrated,
 - b. it has not been subjected to accident, misuse, abuse, improper service, or non-Precor modification.
 - c. claims are made within the warranty period.
2. Certain products are warranted for standard commercial use only (defined as use in non-fee paying clubs or facilities and less than 6 hours daily use. Unapproved use voids the warranty. Current standard commercial products include C936i, C932i, EFX524i, EFX534i.).
3. This warranty does not cover damage or equipment failure caused by electrical wiring not in compliance with electrical codes or Precor owner's manual specifications, or failure to provide reasonable and necessary maintenance as outlined in the owner's manual.
4. Except in Canada, Precor does not pay labor outside the United States.
5. Warranties outside the United States and Canada may vary. Please contact your local Dealer for details.

This Limited Warranty shall not apply to:

1. Software (PROM) version upgrades.
2. Normal wear and tear, consumables and cosmetic items, including, but not limited to the following: grips, seats, and labels.
3. Repairs performed on Precor equipment missing a serial number or with a serial tag that has been altered or defaced.
4. Service calls to correct installation of the equipment or instruct owners on how to use the equipment.
5. Pickup and delivery involved with repairs.
6. Any labor costs incurred beyond the applicable labor warranty period.

Complete this portion and keep for your records.

Purchased From: _____ Example: Dealer or store name.

Phone Number: _____ Example: Dealer or store telephone number.

Product/model: _____ Example: EFX534i or C966i

Serial number: _____

The serial number is found on the shipping container.

Disclaimer and Release.

The warranties provided herein are the exclusive warranties given by Precor and supersede any prior, contrary or additional representations, whether oral or written. ANY IMPLIED WARRANTIES, INCLUDING THE WARRANTY OF MERCHANTABILITY OR FITNESS FOR A PARTICULAR PURPOSE THAT APPLY TO ANY PARTS DESCRIBED ABOVE ARE LIMITED IN DURATION TO THE PERIODS OF EXPRESS WARRANTIES GIVEN ABOVE FOR THOSE SAME PARTS. PRECOR HEREBY DISCLAIMS AND EXCLUDES THOSE WARRANTIES THEREAFTER. Some States do not allow limitations on how long an implied warranty lasts, so the above limitation may not apply to you. PRECOR ALSO HEREBY DISCLAIMS AND EXCLUDES ALL OTHER OBLIGATIONS OR LIABILITIES, EXPRESS OR IMPLIED, ARISING BY LAW OR OTHERWISE, WITH RESPECT TO ANY NONCONFORMANCE OR DEFECT IN ANY PRODUCT, INCLUDING BUT NOT LIMITED TO: (A) ANY OBLIGATION, LIABILITY, RIGHT, CLAIM OR REMEDY IN TORT, WHETHER OR NOT ARISING FROM THE NEGLIGENCE OF PRECOR OR ITS SUPPLIERS (WHETHER ACTIVE, PASSIVE OR IMPUTED); AND (B) ANY OBLIGATION, LIABILITY, RIGHT, CLAIM OR REMEDY FOR LOSS OF OR DAMAGE TO ANY EQUIPMENT. This disclaimer and release shall apply even if the express warranty set forth above fails of its essential purpose.

Exclusive Remedies.

For any product described above that fails to conform to its warranty, Precor will provide, at their option, one of the following: (1) repair; (2) replacement; or (3) refund of the purchase price. Precor Limited Warranty service may be obtained by contacting the authorized dealer from whom you purchased the item. Precor compensates Servicicers for warranty trips within their normal service area to repair commercial equipment at the customer's location. You may be charged a trip charge outside the service area. THESE SHALL BE THE SOLE AND EXCLUSIVE REMEDIES OF THE BUYER FOR ANY BREACH OF WARRANTY.

EXCLUSION OF CONSEQUENTIAL AND INCIDENTAL DAMAGES.

PRECOR AND/OR ITS SUPPLIERS SHALL HAVE NO OBLIGATION OR LIABILITY, WHETHER ARISING IN CONTRACT (INCLUDING WARRANTY), TORT (INCLUDING ACTIVE, PASSIVE, OR IMPUTED NEGLIGENCE AND STRICT LIABILITY), OR OTHERWISE, FOR DAMAGE TO THE EQUIPMENT, PROPERTY DAMAGE, LOSS OF USE, REVENUE OR PROFIT, COST OF CAPITAL, COST OF SUBSTITUTE EQUIPMENT, ADDITIONAL COSTS INCURRED BY BUYER (BY WAY OF CORRECTION OR OTHERWISE) OR ANY OTHER INCIDENTAL, SPECIAL, INDIRECT, OR CONSEQUENTIAL DAMAGES, WHETHER RESULTING FROM NONDELIVERY OR FROM THE USE, MISUSE OR INABILITY TO USE THE PRODUCT. This exclusion applies even if the above warranty fails of its essential purposes and regardless of whether such damages are sought for breach of warranty, breach of contract, negligence, or strict liability in tort or under any other legal theory. Some states do not allow the exclusion or limitation of incidental or consequential damages, so the above limitation may not apply to you.

This warranty gives you specific legal rights, and you may also have other rights, which vary from state to state.

C846i Self-powered Commercial Cycle featuring Heart Rate and SmartRate Systems

Product Specifications

Length: Upright 54 in (137 cm): Recumbent 56 in (142 cm)
Width: Upright 24 in (61 cm): Recumbent 24 in (61 cm)
Height: Upright 53 in (135 cm): Recumbent 48 in (122 cm)
Weight: Upright 127 lb (57 kg): Recumbent 152 lb (68 kg)
Shipping weight: Upright 142 lb (64 kg): Recumbent 167 lb (75 kg)
Resistance: 1 to 25
Power: Self
Frame: Powder-coated steel
Regulatory Approval: FCC, ETL, CE

C846i Features:

CSAFE
Heart Rate Telemetry
QuickStart™
SmartRate®
Touch Heart Rate
Touch-Sensitive Display

Electronic Specifications

C846i Programs: 14

Manual program
Cross Country program
Hill Climb Program
Random Program
3 Interval programs
Watts Control program
Heart Rate Control program*
Weight Loss program*
Resistance Custom program
2 Goal programs (Distance and Calories)
Fitness Test

C846i Display Readouts:

SmartRate *
Heart Rate*
Profile
Time
Remaining Time
Segment Time
Distance
Speed
Resistance
RPM
METs
Calories
Watts
Calories Per Minute

* The user must hold onto both touch-sensitive grips on the handlebars. Or, the user must wear a chest strap. The chest strap is an option available through your dealer.



Precor Incorporated
20031 142nd Avenue NE
P.O. Box 7202
Woodinville, WA USA 98072-4002

Precor, C, CrossRamp, EFX, M, Move Beyond, and SmartRate are registered trademarks of Precor Incorporated. Crosstrainer, QuickStart, and StretchTrainer are trademarks of Precor Incorporated.
Copyright 2004 Precor Incorporated.
Specifications subject to change without notice.
www.precor.com

C846i Lit Kit# 45701-105
OM# 45702-104
Online OM# 45702-404
Warranty Registration# 45622-101
Warranty# 36286-111
01 December 2004

NOTICE:

Precor is widely recognized for its innovative, award winning designs of exercise equipment. Precor aggressively seeks U.S. and foreign patents for both the mechanical construction and the visual aspects of its product design. Any party contemplating the use of Precor's product designs is hereby forewarned that Precor considers the unauthorized appropriation of its proprietary rights to be a very serious matter. Precor will vigorously pursue all unauthorized appropriation of its proprietary rights.